

REVISIONS

ZONE	REV.	DESCRIPTION	DATE	APPROVED
	K	6500-152 Base was 6500-150, 9350-100 Control Box was 6500-100, 6500-106 Switch box Mount was 6500-105, 6500-453 Cover Front was 6500-450, 6500-453 Cover Back was 6500-460, 6500-006 Lexan Panel was 6500-005, Add 2601-355 Nylon Spacer(3), Add 6500-284 Lock Panel, Add 6500-025 Bolt (2), 2620-494 Jam Nut (2)	9/9/14	DC
	L	Add Bushing plate 6500-123	1/14/15	DC
	M	Added 9200-190 Resistor Kit UL325	12/1/16	PSK
Pg2	N	In Sub-Assy 6500-400 added 6500-156 Hub Assy w/Extension Shaft, Remove 6500-155 Hub, 6500-147 Extension Shaft and 2616-099 Set Screw 2X, Add 6500-123 Bushing Lock Plate	4/29/15	DC

6500-440 Cover Turret Assembly

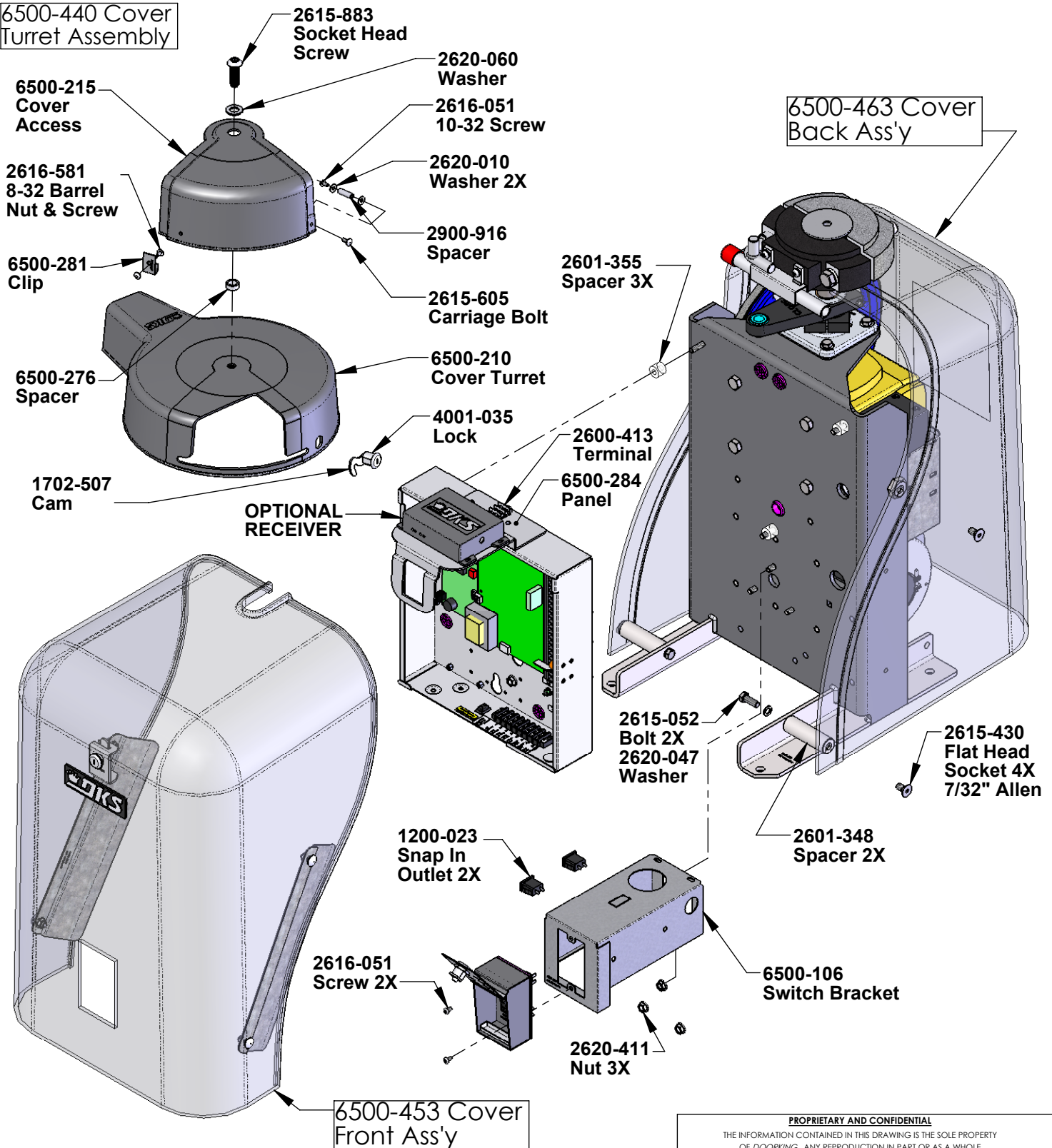

- 4. Item 9200-190 Resistor Kit UL325
 - 3. Item 6500-066 Manual Installation Quick Install
 - 2. Item 6500-065 Manual Installation Swing Gate
 - 1. Item 6500-043 Wire Set
- Included with Operator not Shown.

Notes: Unless Otherwise Specified.

PROPRIETARY AND CONFIDENTIAL

THE INFORMATION CONTAINED IN THIS DRAWING IS THE SOLE PROPERTY OF DOORKING. ANY REPRODUCTION IN PART OR AS A WHOLE WITHOUT THE WRITTEN PERMISSION OF DOORKING IS PROHIBITED.

www.doorking.com

**IPB- Swing Gate Operator
115V 1HP Primary Model 6500-084**

SIZE	A	DWG. NO.	6500-884	REV.	N
Scale: None			SHEET 1 OF 4		

**6500-410
Hub Assy**

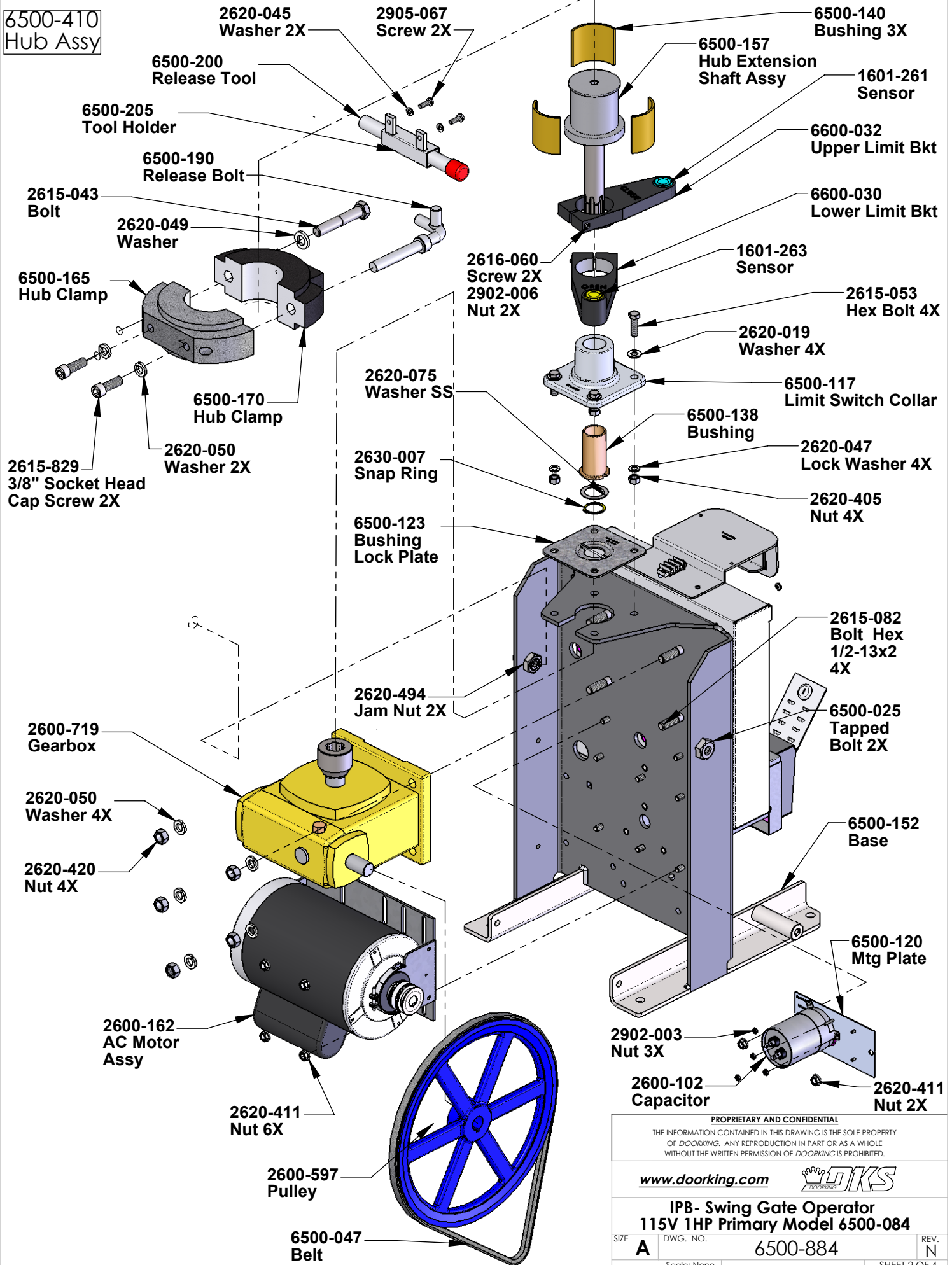

PROPRIETARY AND CONFIDENTIAL
 THE INFORMATION CONTAINED IN THIS DRAWING IS THE SOLE PROPERTY OF DOORKING. ANY REPRODUCTION IN PART OR AS A WHOLE WITHOUT THE WRITTEN PERMISSION OF DOORKING IS PROHIBITED.

www.doorking.com 

**IPB- Swing Gate Operator
 115V 1HP Primary Model 6500-084**

SIZE	DWG. NO.	REV.
A	6500-884	N

Scale: None SHEET 2 OF 4

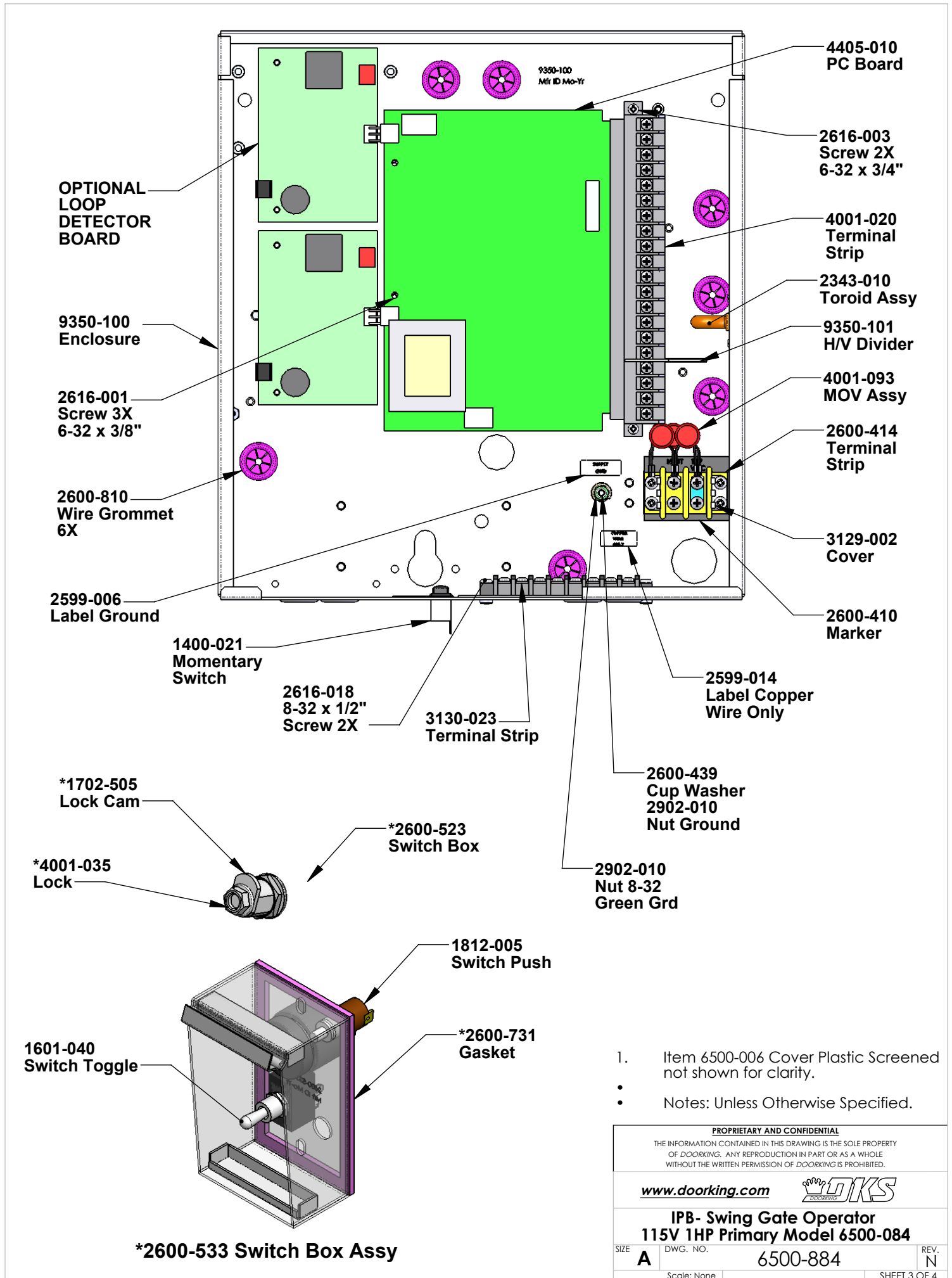

- Item 6500-006 Cover Plastic Screened not shown for clarity.
- Notes: Unless Otherwise Specified.

PROPRIETARY AND CONFIDENTIAL

THE INFORMATION CONTAINED IN THIS DRAWING IS THE SOLE PROPERTY OF DOORKING. ANY REPRODUCTION IN PART OR AS A WHOLE WITHOUT THE WRITTEN PERMISSION OF DOORKING IS PROHIBITED.

www.doorking.com

IPB- Swing Gate Operator
115V 1HP Primary Model 6500-084

SIZE	DWG. NO.	REV.	
A	6500-884	N	N
Scale: None		SHEET 3 OF 4	

6500-430 Full
Assembly
Main Arm

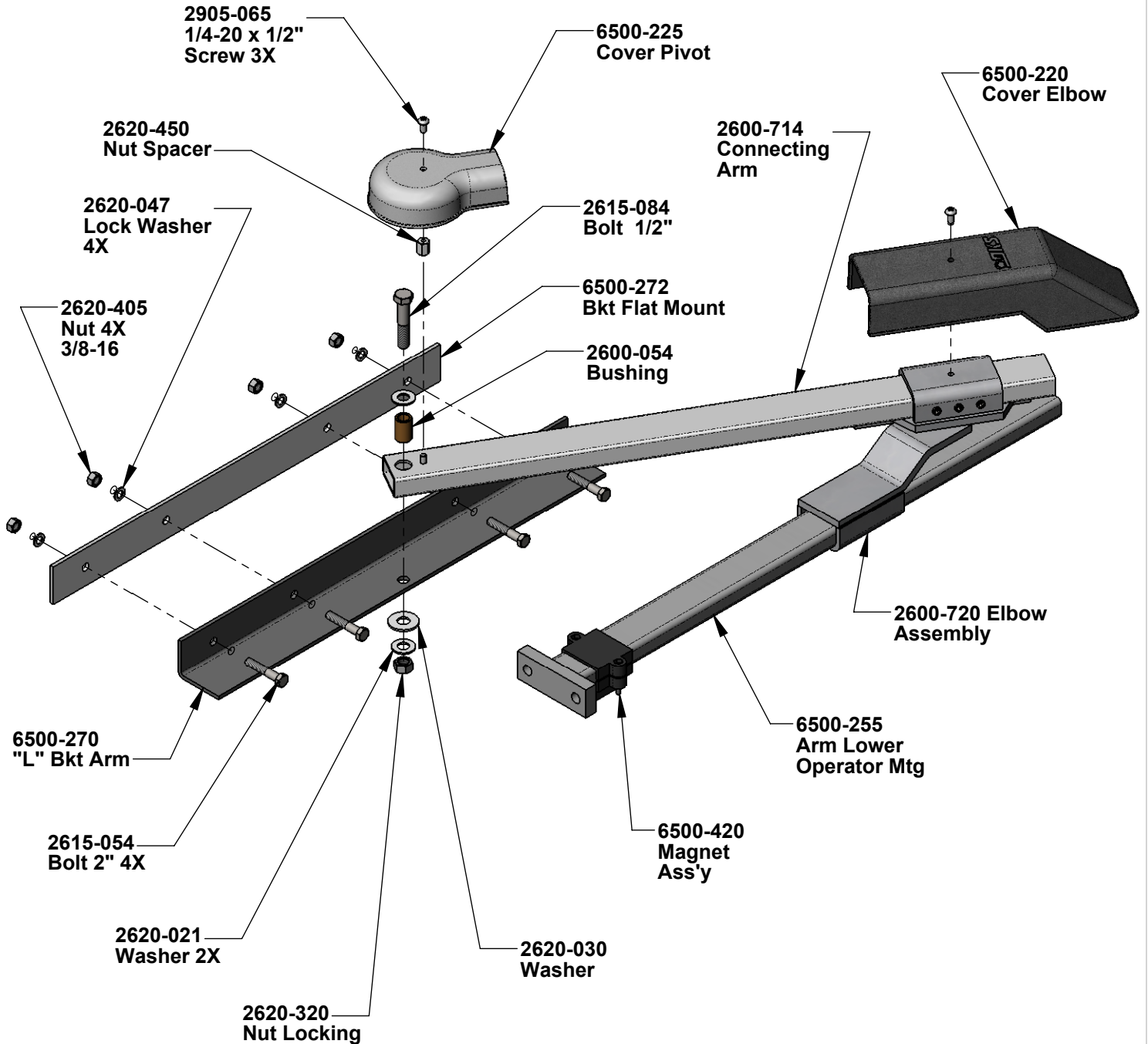

Notes: Unless Otherwise Specified.

PROPRIETARY AND CONFIDENTIAL

THE INFORMATION CONTAINED IN THIS DRAWING IS THE SOLE PROPERTY OF DOORING. ANY REPRODUCTION IN PART OR AS A WHOLE WITHOUT THE WRITTEN PERMISSION OF DOORING IS PROHIBITED.

www.dooring.com 

**IPB- Swing Gate Operator
115V 1HP Primary Model 6500-084**

SIZE	DWG. NO.	REV.
A	6500-884	N
<small>Scale: None</small>		<small>SHEET 4 OF 4</small>