

BLSW2212

Vehicular Gate Operator

INSTALLATION INSTRUCTION & OWNER'S MANUAL



PLATINUM ACCESS SYSTEMS™

BLSW22 I 2

Vehicular Gate Operator

Class I, Class II, Class III, and Class IV

Safety Information	2-7
Gate Operator Class Categories and Examples	8
Contact Safety Sensor and Non-Contact Safety Sensor Installation	9
Installation	10
Inductive Loops.....	11-12
Alert Reset Switch & Warning Placards	13
Plan of Installation.....	14-17
ElecTrical	18-19
Limit Switch Setup	20-21
Primary/Secondary Connections.....	22
Loop Rack.....	23
Accessory Connections	24-27
Selectable Features.....	28-29
Solar Installation	30
Maintenance.....	31
Gate Operator Troubleshooting Procedure	32-33
Parts.....	34
Field Wiring Diagram For BLGOC-2400 Board	35
BLGOC-2400LDR Safety Photoeye Connection	36
BLGOC-2400LDR UL Photoeye Connection For Primary/Secondary Gates.....	37
Platinum ETL Approved External Sensors	38
Swing Operator Mounting Installation Reference.....	39-41
PL-JS-181 Receiver Installation & Program Procedure	42-43
Photoeye Sensor Alignment Installation Instructions	44



WARNING: To reduce the risk of severe injury or death to person, please to follow these instructions:

1. READ AND FOLLOW ALL INSTRUCTIONS MANUAL BEFORE ATTEMPTING ANY INSTALLATION.
2. Should never let children play with gate controls. Keep the remote control away from children.
3. Always keep people and objects away from the gate. "NO ONE SHOULD CROSS THE PATH OF THE MOVING GATE".
4. Check and test the gate operator monthly. The gate MUST reverse on contact with a rigid object or when an object activates the non-contract sensors. After adjusting the force or the limit of travel, retest the gate operator. Failure to adjust and retest the gate operator properly can increase the risk of injury or death.
5. The gate system MUST be maintained properly. Have a qualified service person inspect, repair or adjust your system if any unusual behavior is observed or suspected.
6. Some companies offer a scheduled preventive maintenance service.
7. DO NOT EXCEED the equipment specifications.
8. Insure a safe and proper installation.
9. Install this equipment in accordance with the UL 325 specifications.
10. 10. All installation MUST have secondary protection devices against entrapment, such as edge sensors and photo beams especially in places where the risk of entrapment is more likely to occur.
11. Gate is for vehicles only, a separate entrance for pedestrians is required.
12. Install only on properly operating and balanced door. A door that is operating improperly could cause severe injury. Have qualified service personnel make repairs to cables and other hardware before installing the operator.

SAFETY DEVICES

1. Remove the Power Harness for the control board.
2. Check that all mounting hardware of the gate operator is properly tightened.
3. Ensure that the gate moves freely.
4. Check the battery for the following:
Battery connections must be free of corrosion.
Battery voltage must be 26.5 VDC minimum (fully charged battery).
5. Reconnect the Power Harness for the control board.
6. Make sure every installation has a minimum of one safety device (such as photo beams or loop detector).
7. Check for Reverse Sensitivity.
8. Make sure that all areas around the gate are safe and secure.



WARNING: To reduce the risk of severe injury or death to person, please to follow these instructions:

GENERAL SAFETY PRECAUTIONS WITH THE END-USER:

1. Instruct the end-user on how to safely operate all functions of the operator.
2. Instruct the end-user on how to safely use the Back-drive/ Emergency Release Options.
3. Clearly label and identify the circuit breaker for the operator and show the End-User the location of the circuit breaker for the operator.
4. Thoroughly explain any and all warranties associated with the operator and installation.
5. These instructions must be kept for reference and forwarded to all possible future users of the system.
6. Provide the End-User with the "Home Owner's Manual Guide".
7. The Manufacturer cannot be held responsible for possible damage caused by improper, erroneous or unreasonable use.
8. All cleaning, maintenance of repair work must be carried out by qualified personnel.
9. Failure to comply with the above may create a situation of danger.
10. All installation, maintenance and repair work must be documented and made available to the user.
11. When gate is moving, do not:
 - a. Allow any children to play near the moving gate.
 - b. Attempt to obstruct the moving gate.
 - c. Allow any one get close to the moving gate.

Installer: _____

Signature: _____

Date: _____

Contact: _____

12. Keep remote control, or any other gate operator remote devices away from the children.
13. If operator breakdown, or malfunction, please disconnect the operator from the main power source.
14. Do not attempt to repair, or intervene directly by any one except a qualify personnel.

IMPORTANT INSTALLATION INSTRUCTIONS BY UL STANDARDS:

1. Install the vehicular gate operator only when:
 - a. The gate operator is appropriate for the construction of the gate and the usage class of the gate.
 - b. All exposed pinch points are eliminated or guarded.
2. The gate operator is intended for installation only on gates used for vehicles. Pedestrians must be supplied a separate access opening.
 - a. The pedestrian access opening shall be designed to promote pedestrian usage. Locate the gate such that persons will not come in contact with the vehicular gate during the entire path of travel of the vehicular gate.



WARNING: To reduce the risk of severe injury or death to person, please to follow these instructions:

3. The gate must be installed in a location so that enough clearance is supplied between the gate and adjacent structures when opening and closing to reduce the risk of entrapment. Swinging gates shall not open into public access areas.
4. The gate must be properly installed and work freely in both directions prior to the installation of the gate operator. Do not over-tighten the arm clamp to compensate for a damaged or poorly maintained gate.
5. The gate operator controls must be placed so that the user has full view of the gate area when the gate is moving and away from the gate path perimeter.
6. Controls intended for user activation must be located at least six feet (6') away from any moving part of the gate and where the user is prevented from reaching over, under, around or through the gate to operate the controls and shall be at least (5') from the ground as to be out of reach of children. Outdoor or easily accessible controls shall have a security feature to prevent unauthorized use. Also:
 7. Ensure the Stop and/or Reset button must be located in the line-of-sight of the gate following rules above. Activation of the reset control shall not cause the operator to start.
8. A minimum of two (2) Warning Placards shall be mounted, one on each side of the gate where easily visible.
9. A gate operator utilizing a non-contact sensor such as an Photo beam or like in accordance with section 31.1.1 of the UL325 standard:
 - a. Reference owner's manual regarding placement of non-contact sensor for each type of application.
 - b. Care shall be exercised to reduce the risk of nuisance tripping, such as when a vehicle trips the sensor while the gate is still.
 - c. One or more non-contact sensors shall be located where the risk of entrapment or obstruction exists, such as the perimeter reachable by a moving gate or barrier.
 - d. We recommend (EMX IRB-325) use as a fail safe photoeye to comply with UL325.
10. A gate operator utilizing a contact sensor such as an edge sensor or like in accordance with section 31.1.1 of the UL325 standard:
 - a. A hard wired contact sensor shall be located and its wiring arranged so the communication between the sensor and the gate operator is not subject to mechanical damage.
 - b. A wireless contact sensor such as the one that transmits radio frequency (RF) signals to the gate operator for entrapment protection functions shall be located where the transmission of the signals are not obstructed or impeded by building structures, natural landscaping or similar obstruction. A wireless contact sensor shall function under the intended end-use conditions.
 - c. One or more contact sensors shall be located on the inside and outside leading edge of a swing gate. Additionally, if the bottom edge of a swing gate is greater than 6 inches (152 mm) above the ground at any point in its arc of travel, one or more contact sensors shall be located on the bottom edge.
 - d. The following model(s) are comply with UL 325: Miller Edge model MGR20 or MGS20 edge sensor.



WARNING: To reduce the risk of severe injury or death to person, please to follow these instructions:

IMPORTANT INSTALLATION INSTRUCTIONS BY UL STANDARDS:

a) Install the gate operator only when:

1. The operator is appropriate for the construction of the gate and the usage Class of the gate,
2. All openings of a horizontal slide gate are guarded or screened from the bottom of the gate to a minimum of 1.83 M (6 ft) above the ground to prevent a 57.2mm (2-1/4 inch) diameter sphere from passing through the openings anywhere in the gate, and in that portion of the adjacent fence that the gate covers in the open position,
3. All areas of the moving vertical pivot gate panel from the bottom of the gate to the top of the gate or a minimum of 1.83 m (72 in) above grade, whichever is less, that pass by a fixed stationary object, and in the area of the adjacent fence that the gate covers during the travel of the gate, shall be designed, guarded or screened to prevent a 57mm (2-114 in) diameter sphere from passing through such areas.
4. All exposed pinch points are eliminated or guarded, and
5. Guarding is supplied for exposed rollers.
6. The operator instructions shall list the maximum number of open and close entrapment protection devices capable of being connected to the operator.

b) The operator is intended for installation only on gates used for vehicles. Pedestrians must be supplied with a separate access opening. The pedestrian access opening shall be designed to promote pedestrian usage. Locate the gate such that persons will not come in contact with the vehicular gate during the entire path of travel of the vehicular gate.

c) The gate must be installed in a location so that enough clearance is supplied between the gate and adjacent structures when opening and closing to reduce the risk of entrapment. Swinging gates shall not open into public access areas.

d) The gate must be properly installed and work freely in both directions prior to the installation of the gate operator, Do not over-tighten the operator clutch or pressure relief valve to compensate for an improperly installed, improperly functioning, or damaged gate.

e) For gate operators utilizing Type D protection:

1. The gate operator controls must be placed so that the user has full view of the gate area when the gate is moving,
2. The placard as required by 62.1.6 shall be placed adjacent to the controls,
3. An autoatic closing device (such as a timer, loop sensor, or similar device) shall not be employed, and
4. No other activation device shall be connected.

f) Permanently mounted controls intended for user activation must be located at least 1.83 in (6ft) away from any moving part of the gate and where the user is prevented from reaching over, under, around or through the gate to operate the controls. Exception: Emergency access controls only accessible by authorized personnel (e.g. fire, police, EMS) may be placed at any location in the line-of-sight of the gate.

g) The Stop and/or Reset button must be located in the line-of-sight of the gate. Activation of the reset control shall not cause the operator to start.



WARNING: To reduce the risk of severe injury or death to person, please to follow these instructions:

h) A minimum of two (2) WARNING SIGNS shall be installed, in the area of the gate. Each placard is to be visible by persons located on the side of the gate on which the placard is installed. Also see 62.1.1.

i) For gate operators utilizing a non-contact sensor in accordance with 32.1.1:

1 See instructions on the placement of non-contact sensors for each Type of application,

2 Care shall be exercised to reduce the risk of nuisance tripping, such as when a vehicle. trips the sensor while the gate is still moving, and

3. One or more non-contact sensors shall be located where the risk of entrapment or obstruction exists, such as the perimeter reachable by a moving gate or barrier.

j) For a gate operator utilizing a contact sensor in accordance with 32.1.1:

1. One or more contact sensors shall be located where the risk of entrapment or obstruction exists. such as at the leading edge, trailing edge, and postmounted both inside and outside of a vehicular horizontal slide gate.

2 One or more contact sensors shall be located at the bottom edge of a vehicular vertical lift gate.

3. One or more contact sensors shall be located at the pinch point of a vehicular vertical pivot gate.

4 A hardwired contact sensor shall be located and its wiring arranged so that the communication between the sensor and the gate operator is not subjected to mechanical damage.

5. A wireless device such as one that transmits radio frequency (RE) signals to the gate operator for entrapment protection functions shall be located where the transmission of the signals are not obstructed or impeded by building structures, natural landscaping or similar obstruction. A wireless device shall function under the intended end-use conditions.

6. One or more contact sensors shall be located on the inside and outside leading edge of a swing gate. Additionally, if the bottom edge of a swing gate is greater than 152 mm (6 in) but less than 406 mm (16 in) above the ground at any point in its arc of travel, one or more contact sensors shall be located on the bottom edge.

7. One or more contact sensors shall be located at the bottom edge of a vertical barrier (arm).

8. "Emergency access controls accessible to authorized personnel only, may be placed at any location within line-of-sight of the door."

If the operator must be installed less than 8ft (2.44M) above the floor, then exposed moving parts must be protected by covers or guarding, provided by the operator manufacturer. Locate the control station: (a) within sight of the door, and (b) at a minimum height of 5 feet so small children cannot reach it. Controls intended for user activation must be located at least six feet (6') away from any moving part of the gate and where the user is prevented from reaching over, under, around or through the gate to operate the controls.



WARNING: To reduce the risk of severe injury or death to person, please to follow these instructions:

**FOR USE WITH GATES OF A
MAXIMUM OF 12 FT IN LENGTH
AND 2200 LBS. IN WEIGHT**

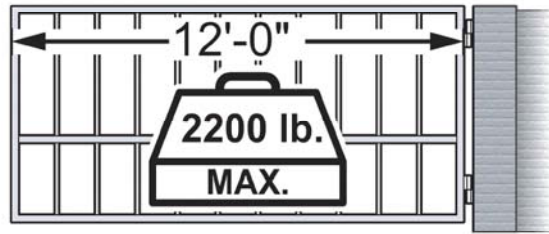

This is NOT a pedestrian gate operator



Do NOT Install the gate operator to lift gates



Control Buttons Location:

1. Within sight of the gate,
2. At a minimum height of 5 feet so small children are not able to reach it, and make sure it is away from all moving parts of the gate.

Specifications

Usage Classification:	Class I, II, III & IV
Maximum Gate Length:	12 feet
Maximum Gate Weight:	2200 lbs
Maximum Aperture Angle:	120 deg.
Power Requirements:	120 VAC Single Phase at 2 Amps or 220 VAC Single Phase at 1 Amp
Operating Temperature:	-20°C (-4°F) to 70°C (158°F)
System Operating Voltage:	24VDC Switching power supply/ Battery Backup
Maximum Daily Cycle rate:	Continuous
Solar Power Capabilities:	Optional



WARNING: To reduce the risk of severe injury or death to person, please to follow these instructions:

CAUTION: TO REDUCE THE RISK OF FIRE OR INJURY TO PERSONS

- Use only the type and size of batteries provided on an AC powered system: OUTDO-0T7-12
- Do not dispose of the batteries in fire. The cells may explode. Check with local codes for possible disposal instructions.
- Do not open or mutilate the operator batteries. Released electrolyte is corrosive and may cause damage to the eyes or skin. It may be toxic if swallowed.
- Exercise care in handling batteries in order not to short the battery with conducting materials such as metal parts, rings, bracelets and keys.
- Do not mix batteries of different sizes, from different manufacturers or of different ages in this product. Replace both batteries as a set.
- Observe proper polarity orientation between the batteries and charging circuit.
- Change the operator batteries provided with or identified for use with this product only in accordance with the instructions and limitations specified in this operator manual.

UL 325 GATE OPERATOR CLASSIFICATION

Install the gate operator only when: The operator is appropriate for the construction of the gate and the Usage Class of the gate.

Residential Vehicular Gate Operator

Class I - A vehicular gate operator (or system) intended for use in a home of one- to four single family dwelling, or a garage or parking area associated therewith.

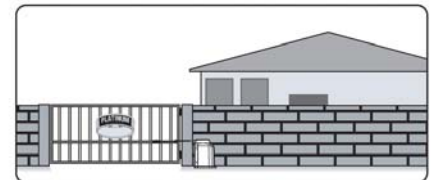

Commercial/General Access Vehicular Gate Operator

Class II - A vehicular gate operator (or system) intended for use in a commercial location or building such a multi-family housing unit (five or more single family units), hotel, garages, retail store, or other building servicing the general public.

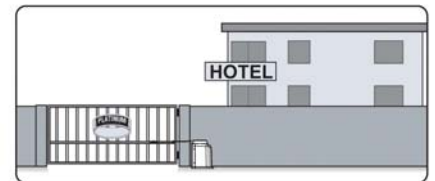

Industrial/Limited Access Vehicular Gate Operator

Class III - A vehicular gate operator (or system) intended for use in an industrial location or building such as a factory or loading dock area or other locations not intended to service the general public.

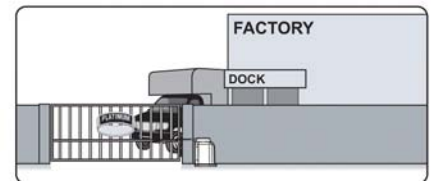

Restricted Access Vehicular Gate Operator

Class IV - A vehicular gate operator (or system) intended for use in a guarded industrial location or building such as an airport security area or other restricted access locations not servicing the general public, in which unauthorized access is prevented via supervision by security personnel.



Contact Safety Sensor and Non-Contact Safety Sensor Installation



WARNING: To reduce the risk of severe injury or death to person, please to follow these instructions:

NOTE: Edge Sensor installation DOES NOT reverse the gate all the way back to its limits when the edge sensor is contacted. This installation is only to protect against entrapment and to comply with UL325.

NOTE: If the bottom edge of a swing gate is more than 6" (152mm) above the ground at any point in its travel on or more sensors shall be located to protect from the bottom edge.

- A wireless contact sensor such as one that transmits radio frequency signals to the gate operator for entrapment protection functions shall be located where the transmission of the signals are not obstructed or impeded by building structures, natural landscaping or similar obstruction. A wireless contact sensor shall function under the intended end-use conditions.
- A hardwired contact sensor shall be located and its wiring arranged so that the communication between the sensor and the gate operator is not subjected to mechanical damage.

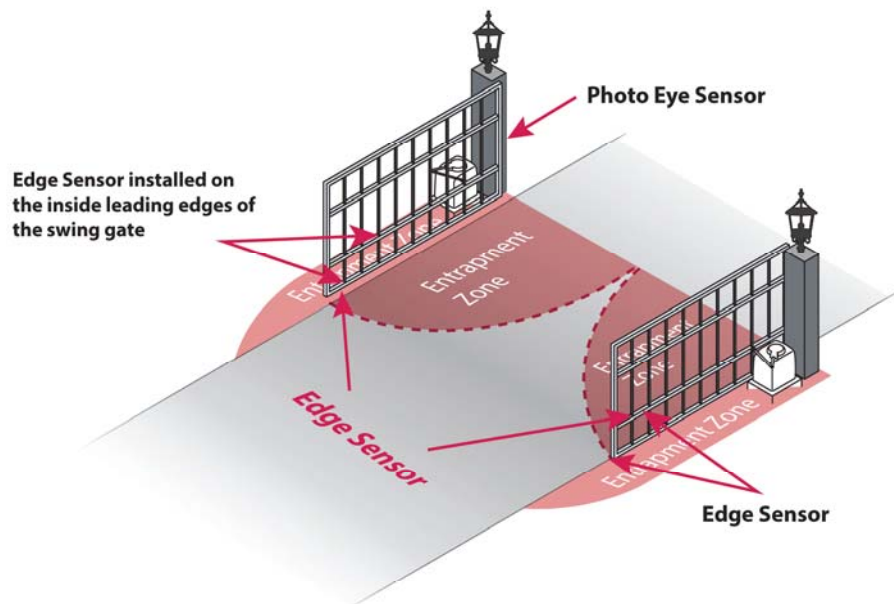

Note: One or more Contact Sensors and Non-Contact Sensors Shall be located on the inside and outside leading edges of a swing gate, or where the risk of entrapment, or obstruction exists' such as the perimeter reachable by a moving gate, or barrier.

Install photo beam sensors and edge sensors to protect against any entrapment or safety conditions encountered in your gate installation.

We recommend to install photo beam sensors for protection at the potential entrapment area like the one shown at the bottom picture.

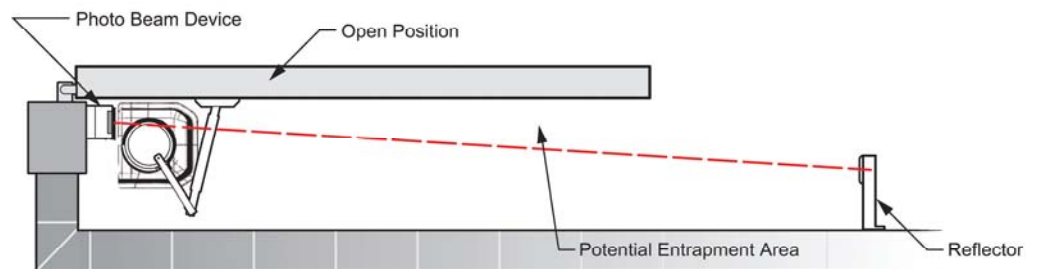

The new 2018 UL 325 standard requires minimum two external safety devices for an operator. One monitors the close cycle, and the other one monitors the open cycle. Most typical installation is to connect one photo eye sensor to CL-EYE terminal and connect an Edge sensor MGL-RX20 to MON-OPEN terminal UL1. You can connect up to four external safety devices to each operator.

STANDARD SWING ARM INSTALLATION POSITION WHEN GATE IS FULLY OPEN

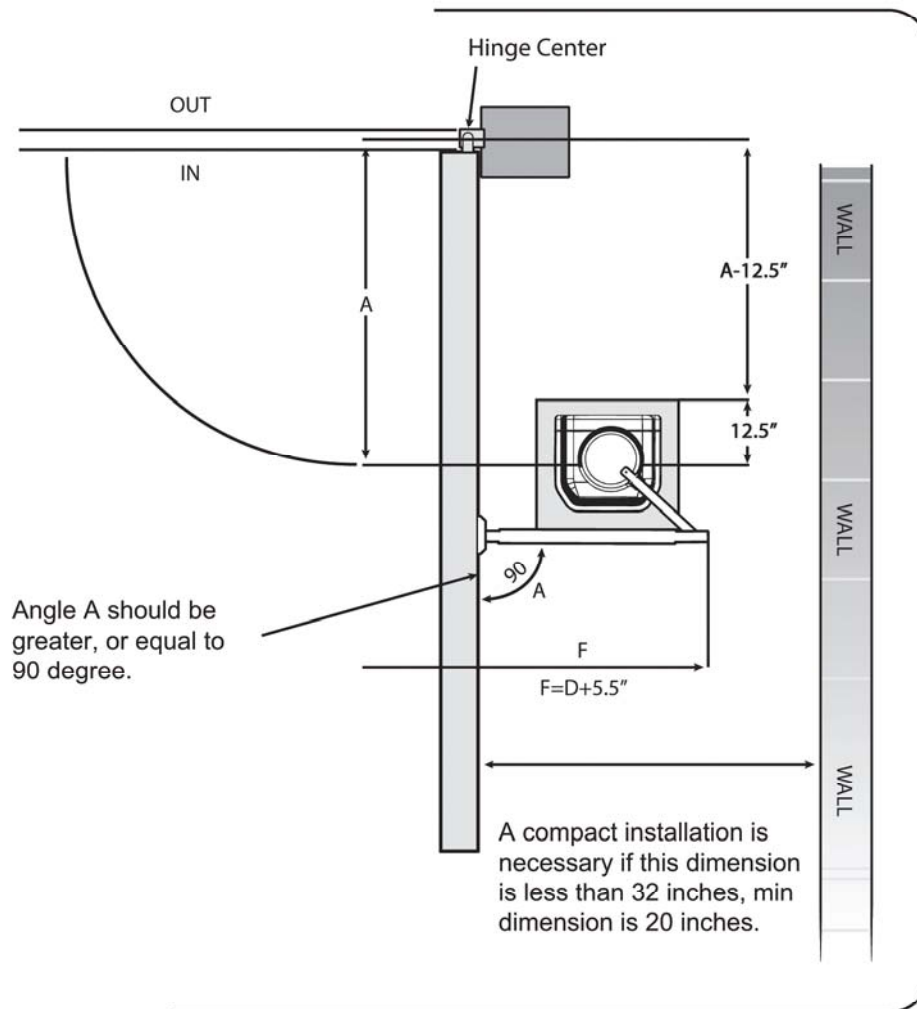

MANUAL RELEASE

Locking Handle
(in Unlocked
Position)

When manual operation is required:

1. Remove the Hat
2. Lift the Locking Handle.
3. Remove the Clutch Key

To reengage the gate operator:

1. Align the Clutch and the notches on the Output Shaft.
2. Insert the Clutch Key.
3. Push down the Locking Handle.
4. Reattach the Hat.

Attention: Lock and release operations MUST be performed with motor NOT RUNNING.



WARNING – Consult the installation instructions from the loop detector manufacturer. The following statements are provided as a guide but different requirements may be required by the vehicular loop detector manufacturer.

INDUCTIVE LOOPS INSTALLATION:

Safety loops allow the gate to stay open when vehicles are obstructing the gate path. If the gate is longer than the vehicles that pass through it a center loop is recommended and should be installed. A center loop prevents the gate from closing when a vehicle is between the safety loops. Safety loops are required when using a center loop. See Loop Wiring.

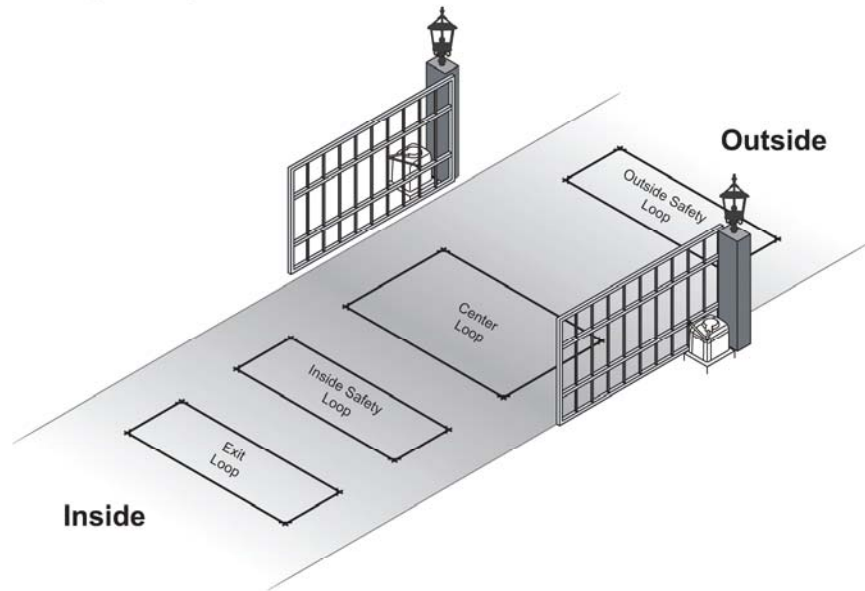

Check with local regulations and accepted best practice requirements for every installation.

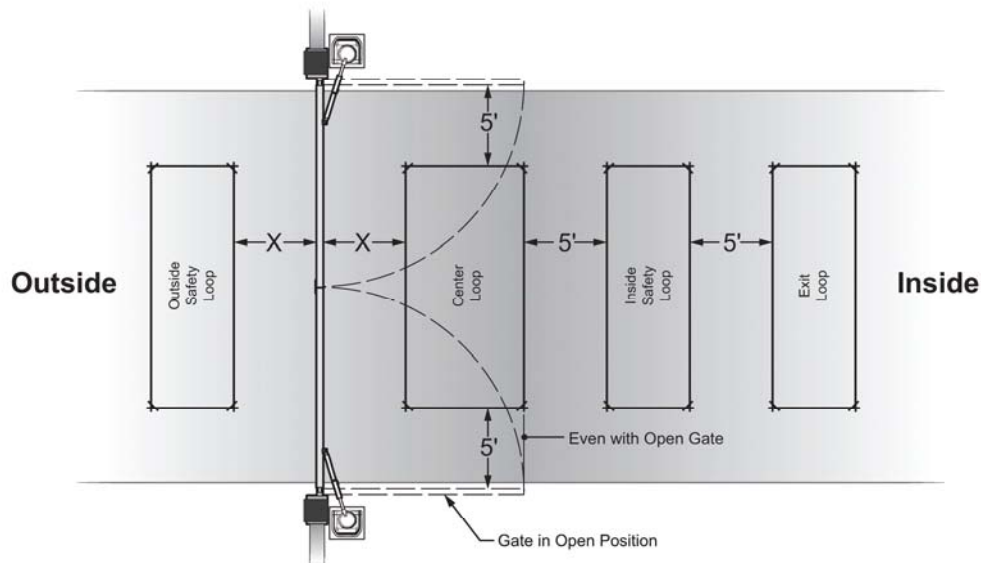



WARNING – This product is an accessory or part of a system. Always read and follow the manufacturer’s instructions for the equipment before connecting this product. Comply with all applicable codes and safety regulations. Failure to do so may result in damage, injury or death.

NEW SLAB POUR

Ty-wrap 1 1/4" PVC Pipe to the top of the rebar in the size and configuration of the loop (i.e. 4ft x 8ft). Then ty-wrap the loop to the top of the PVC frame. This stabilizes the loop during the pour and separates it from the rebar.

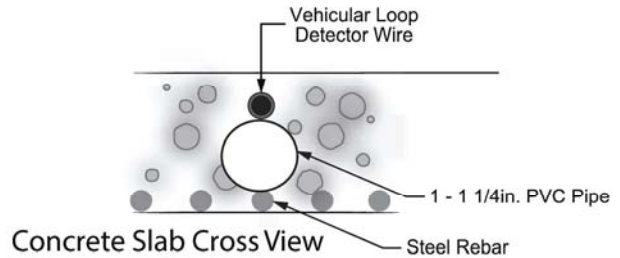

SAW CUT EXISTING SURFACE

Cut 1" deep into the existing surface, place a 45° cut at the corners to prevent sharp edges from damaging the loop wire. Notch out for the "T" connection where the lead wire connects to the loop. Remove all debris from the finished cut with compressed air. Place the loop into the saw cut. Place backer material into the saw cut over the loop wire and pack tightly. Place a high quality sealer over the saw cut to seal the surface.

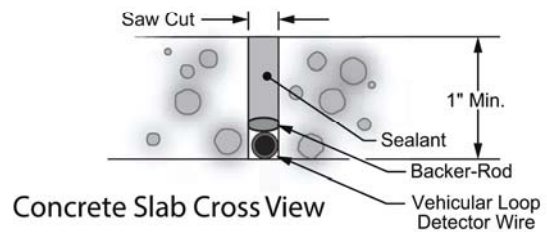

RESURFACE ASPHALT

Saw cut the existing surface 3/4" deep and place a 45° cut at the corners to prevent sharp edges from damaging the loop wire. Remove all debris from the finished cut with compressed air. Place sand over the loop wire to the surface and pack tightly. Lay new asphalt.

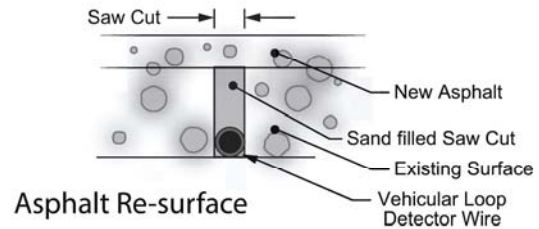

GENERAL INSTALLATION GUIDELINES

Lead-in wire (wire from loop to detector) must be twisted a minimum of 6 turns/ foot to avoid the effects of noise or other interference.



Detection height is approximately 70% of the shortest side of the loop.

Recommended # of Turns

Perimeter in Feet	# of Turns
10	5
20	4
30-40	3
50-100	2



WARNING – To reduce the risk of severe injury or death to person, please follow these instructions:

ALARM RESET SWITCH INSTALLATION: (UL 325 standard requirement)

An audible alarm to go off after two consecutive events detected by the primary entrapment protection of the gate operator. The audible alarm will continue to sound for 5 minutes or until a stop command gets actuated.

The Stop command can be actuated in two different forms.

1. The Built in Stop switch on the Control Box.
2. The External Stop button within the sight of the gate, away from moving parts of the gate and out of reach of children.

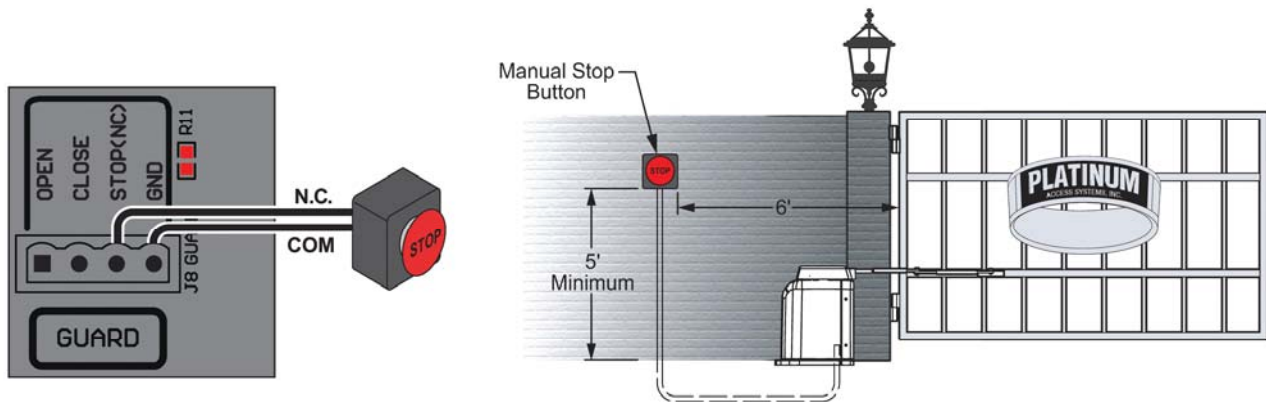

WARNING PLACARDS INSTALLATION:

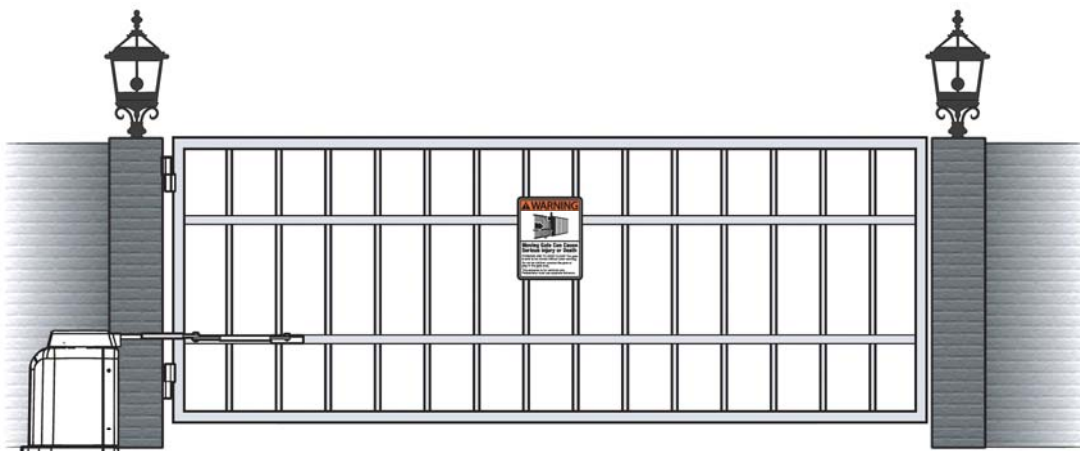

All Warning Signs and Placards must be mounted where visible in the area of the gate.

A minimum of two (2) Warning Placards shall be mounted. (One on each side of the gate).

Plan of Installation:

The gate must be installed in a location so that enough clearance is supplied between the gate and adjacent structures when opening and closing to reduce the risk of entrapment. Swinging gates shall not open into public access areas.

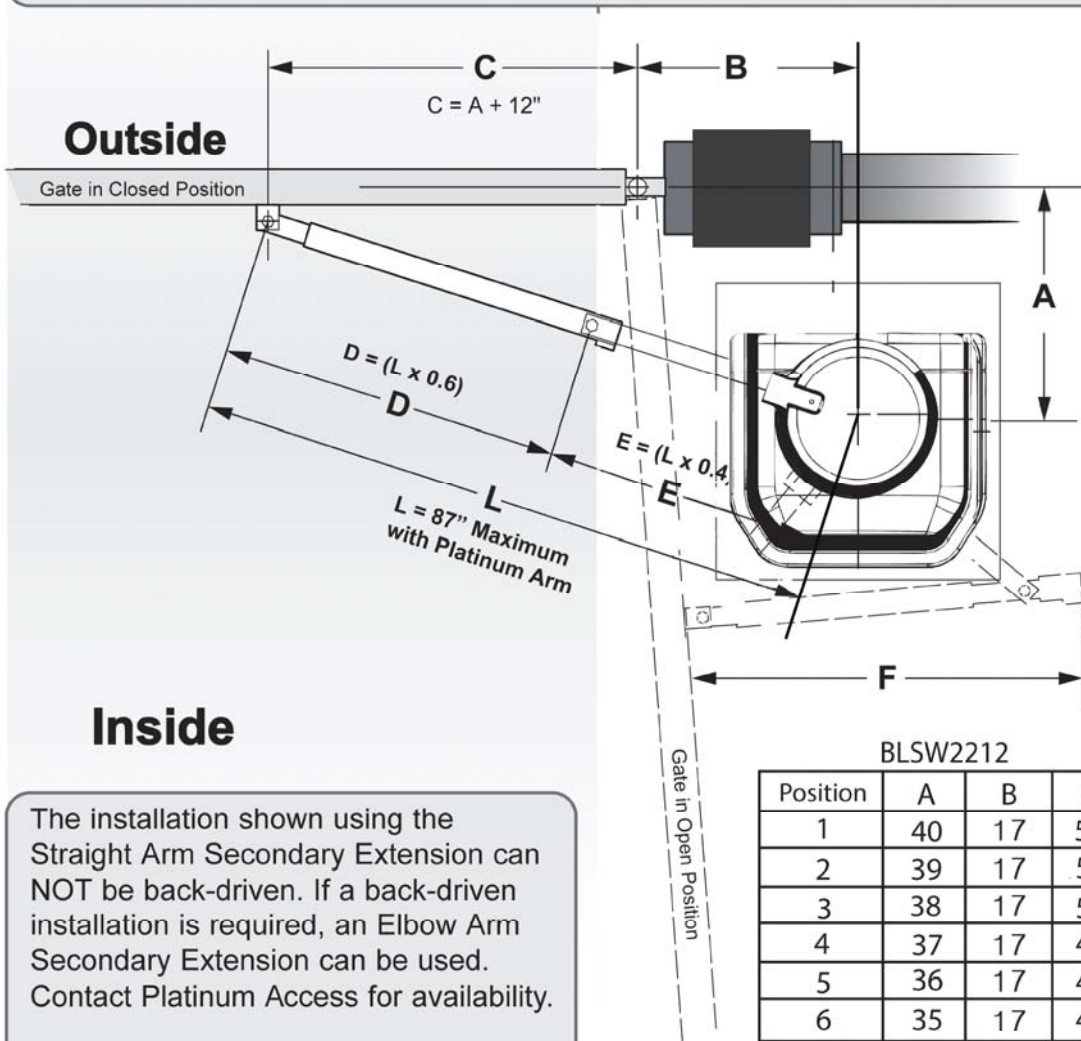

The installation shown using the Straight Arm Secondary Extension can NOT be back-driven. If a back-driven installation is required, an Elbow Arm Secondary Extension can be used. Contact Platinum Access for availability.

**Note:* The dimensions provided are just a guideline. Each site may have different geometries or possibilities of installation. The key for installation is to have "D" longer than "E" and to adjust the arms such that the arm is straight at the closed position.

BLSW2212

Position	A	B	C	D	E
1	40	17	52	47.85	32
2	39	17	51	47	31.35
3	38	17	50	46.21	30.8
4	37	17	49	45.4	30.27
5	36	17	48	44.58	29.72
6	35	17	47	43.77	29.18
7	33	17	45	42.14	28.1

COMPACT INSTALLATION

Position	A	B	C	D	E
1	27	16	36	35.16	23.44

Plan of Installation (continued):

Concrete Pad

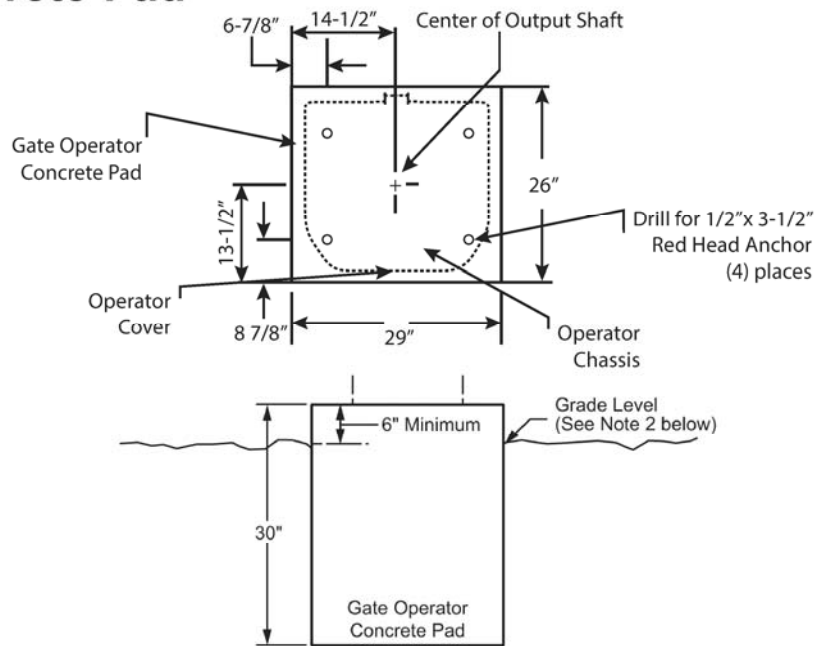

1. Follow the local building code to determine the requirement of the concrete pad.
2. We recommend the Pad measurements should be at least 29" long, 26" wide, and 24" deep to ensure the stable operation of the operator, and a minimum of 4" above level grade to avoid any flooding of the operator.
3. To support the weight of the gate, we recommend the path of the track should be at least 10" wide and 6" deep.

Arm Assembly

Platinum Access Systems can supply an Elbow Arm Secondary Extension (Part # PA-EA100) to make the unit backdrivable. Contact Platinum Access for availability.

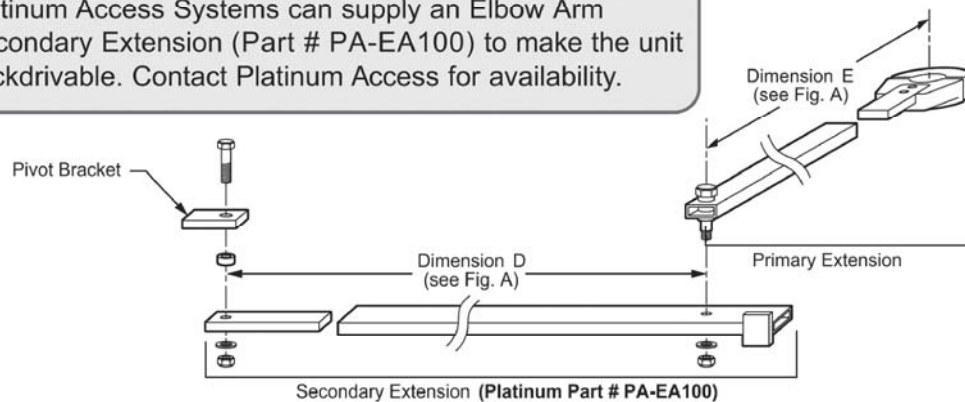

CAUTION

Do not weld the bar or backing plate to only a few gate posts. Mounting bar must be welded to a frame segment that runs the full length of the gate to prevent damage to the gate operator.



STEP 1

Release the clutch (see pg. 7) and cut the extension arms according to the desired plan of installation (Figure A on pg. 12).

Note: Leave extra material when cutting the extension arms to allow for any added adjustment.

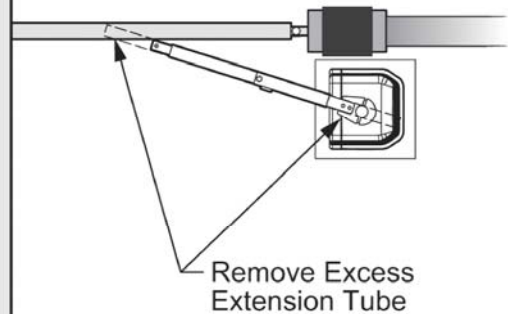

STEP 2

With the gate in the closed position, place the pieces of the articulated arm. Make certain the dimensions correspond to the plan of installation. To aid in the pre-installation process, use C-clamps or tack-weld pieces.

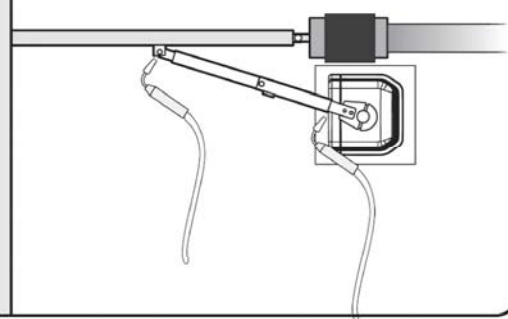

STEP 3

With the clutch released, manually position the gate from completely close to completely open position (Arm is 90 degree to the gate). Confirm the gate/arm combination provides the desired operation and the arm does not bind in it's movement (especially in open position).

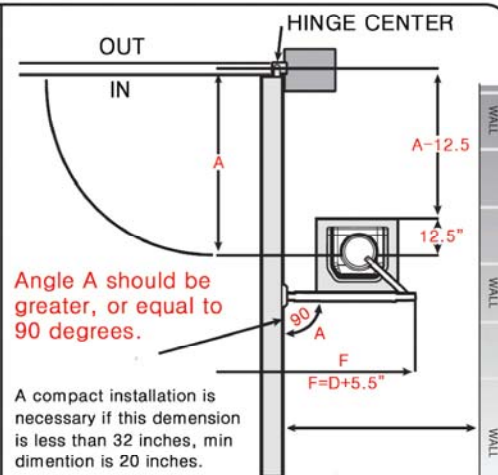

STEP 4

Once satisfied with the arrangement of the articulated arm and bracket, weld all pieces securely.

Paint the arm to preserve it from rusting.

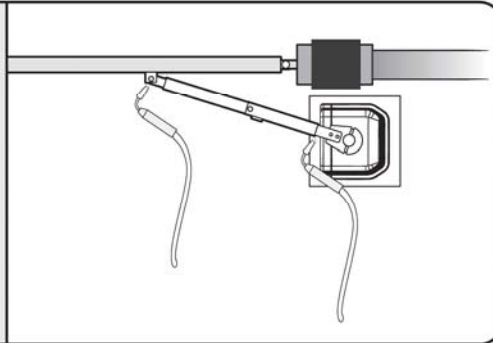

STEP 5

Upon test of the installation, loosen the Arm Clamp and rotate it until it lines up with the notches in the Output Key.

Insert the Output Key.

Note: Do not insert the output key for back-drive capability

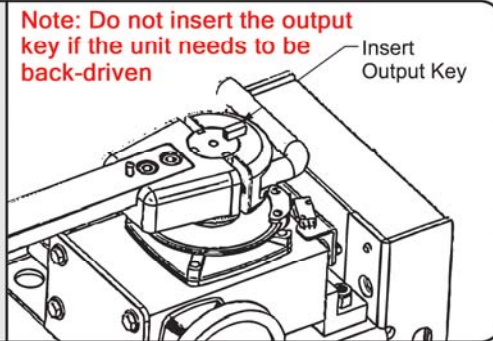

STEP 6

Check the Arm Clamp adjustment. The Arm Clamp is shipped factory adjusted. The Arm Clamp must be tight enough to prevent slippage in normal operation.

Check the tightness of the Arm Clamp:

- A. Remove the Output Key from the Arm Clamp.
- B. Attempt to manually move the gate.
- C. If slippage occurs:
 1. Loosen the Locking Handle
 2. Tighten the opposite bolt.
 3. Tighten the Locking Handle
 4. Check the tightness of the Arm Clamp again.

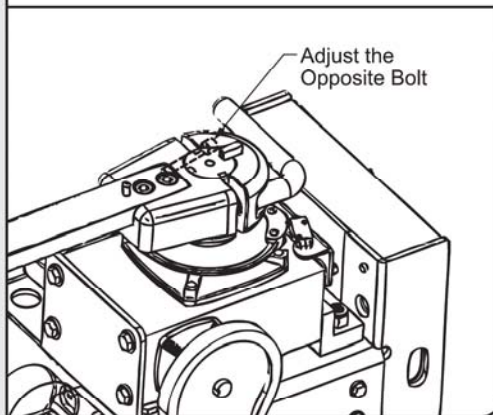
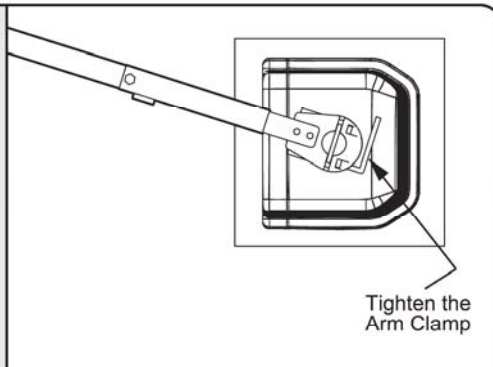



WARNING: Verify the installation first to make sure everything is correct before connection the power cable to the board. USE MIN. 14 AWG WIRE. FOLLOW ALL LOCAL ELECTRICAL CODES.

To help protect the equipment from lightning and power surges and to protect persons from shock hazard the Operator must be grounded. The earth ground rod must be located within 3 feet from the gate operator. Use the proper type earth ground rod for your local area. The ground wire must be a single, whole piece of wire. Never splice two wires for the ground wire. If you cut the ground wire too short, break it, or destroy its integrity, replace it with a single wire length. Prevent unnecessary turns or loops in ground wires.

The gate operator and the battery charger require a single phase AC line to operate.

1. Turn off the breaker for the circuit you are using.
2. Select the proper voltage on the power board.
3. Connect the incoming power wires to the proper terminals.
4. Turn on the breaker and check that AC ON and CHARGE LED are lit.

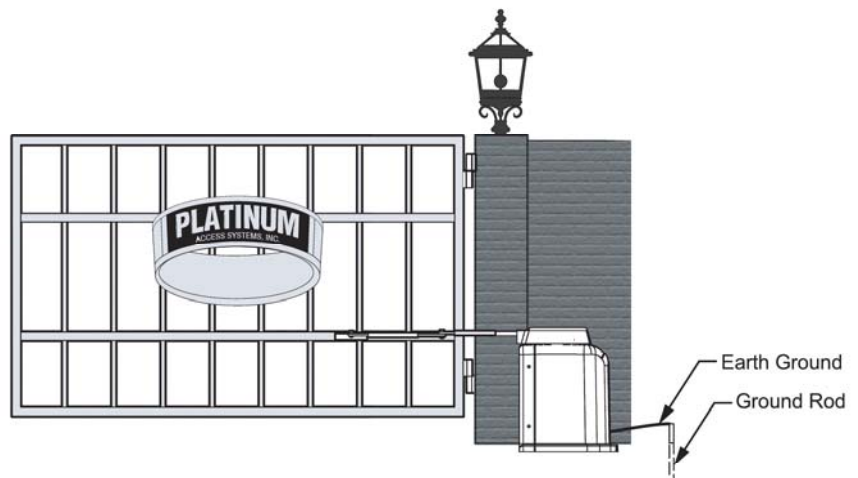
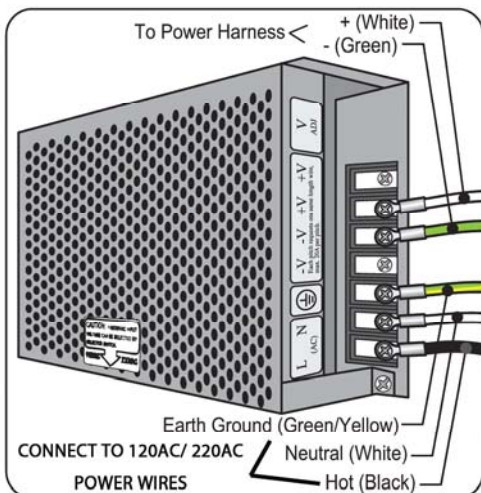
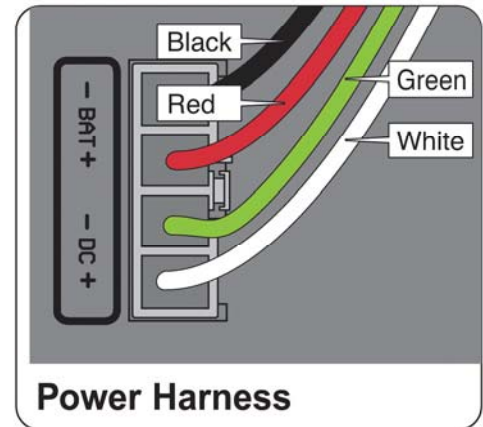

The power receptacle has been left unconnected till the installer decides what voltage to use. Connect to 120VAC only

CONNECTING POWER: (PRE-WIRED)

Connect the LIMIT harness to J14, and MOTOR CTL harness to J4.
 On the OPEN DIR switch: Select "RIGHT" to open right.
 Select "LEFT" to open left.

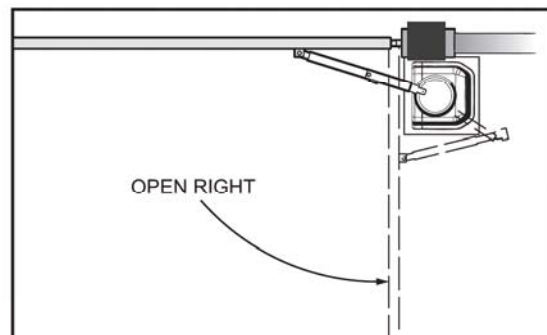
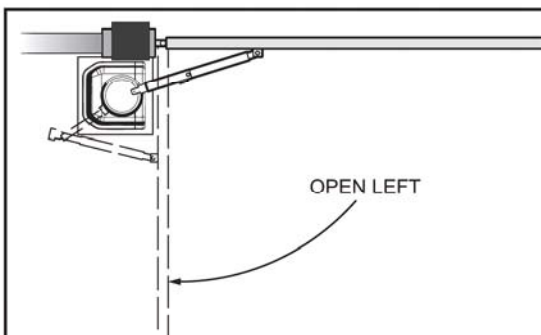
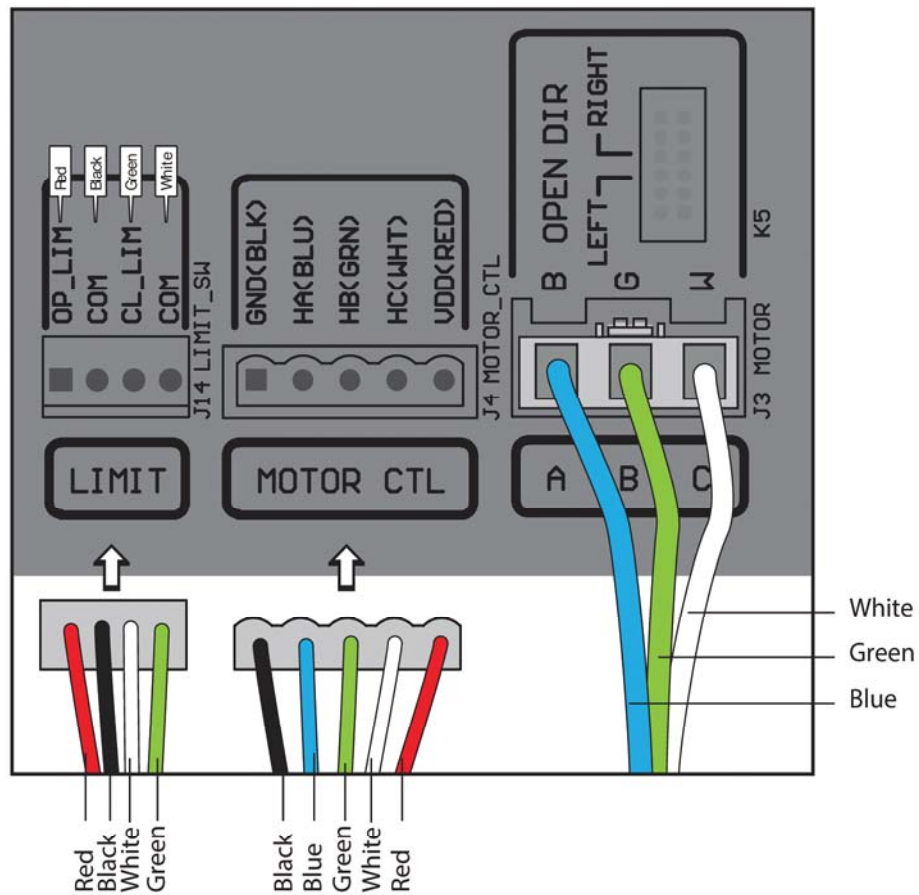

STEP 7

- A. Loosen the screws on the Limit Switch Cams.
- B. Remount the articulated arm, making sure the cam wheel pin is engaged with the clutch.
- C. Move the gate manually to the closed position.
- D. Move the Limit Switch Cams on the Cam Wheel to actuate each limit switch.

Gate Opens to Right

Left Limit Switch	Open limit
Right Limit Switch	Close limit

Gate Opens to Left

Left Limit Switch	Close limit
Right Limit Switch	Open limit

- E. Slightly tighten the screw on the Limit Switch Cam.
- F. Move the gate manually to the open position. Repeat steps a, b and c for the other cam.
- G. Run the unit 2 full cycles without interruption (from limit to limit) to execute a "Learn Cycle."

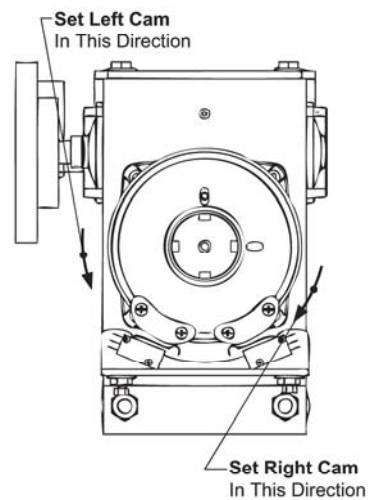
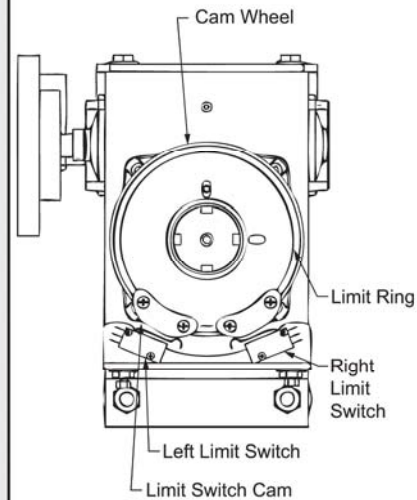

STEP 8

Install the Cover by carefully slipping the front half over the Limit Switches and Cam Wheel., then fitting the back cover in place. Latch the hasps on both sides of the Cover.

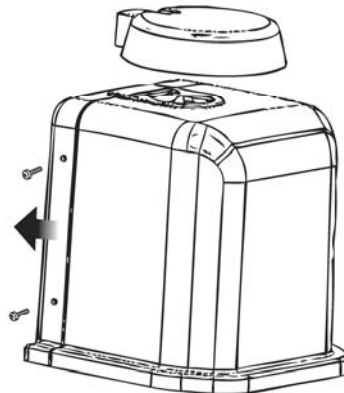

OPENING/CLOSING SETUP

1. Setup the limit switches manually at the desired open and close position.
2. Allow the gate operator to run a full open and close cycle (from limit to limit) without interruption.

Note: During the first full open and close cycle, the gate operator will run at low speed. During subsequent cycles, the gate operator will speed up at start and slow down prior to reaching its limits.

3. Verify that the gate opens and closes to the desired position.

Note: When slightly adjusting the open or close limit position(s), the operator will automatically adapt the changes. When relearning is needed, push and hold "RESET" button for 3 second, the machine will return to original state, and be ready for learning.

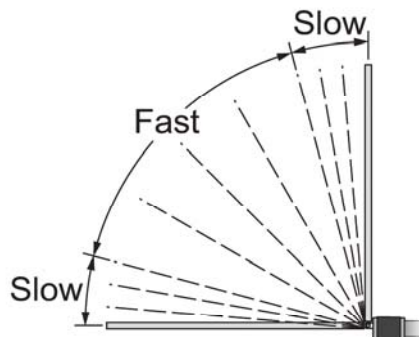

LIMIT SWITCH CONNECTIONS

The Limit Switches are pre-wired. Should the wires become disconnected, use this diagram to reconnect them.

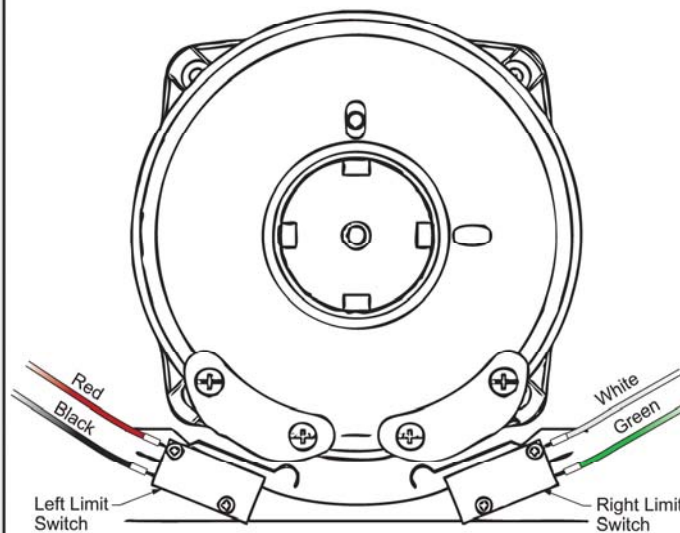

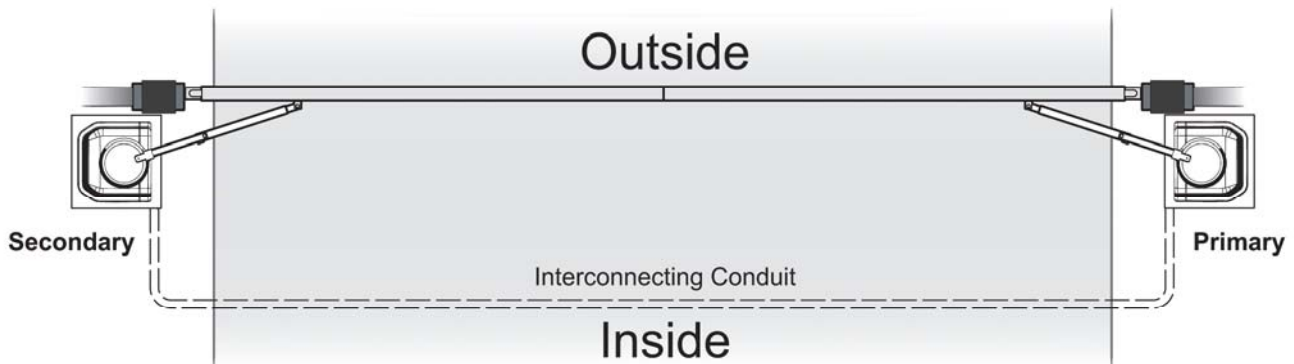

Caution – Do not run Primary/Secondary communication cable (Model #PA-PSC100) in the same conduit as the power supply (120-220V) cable.

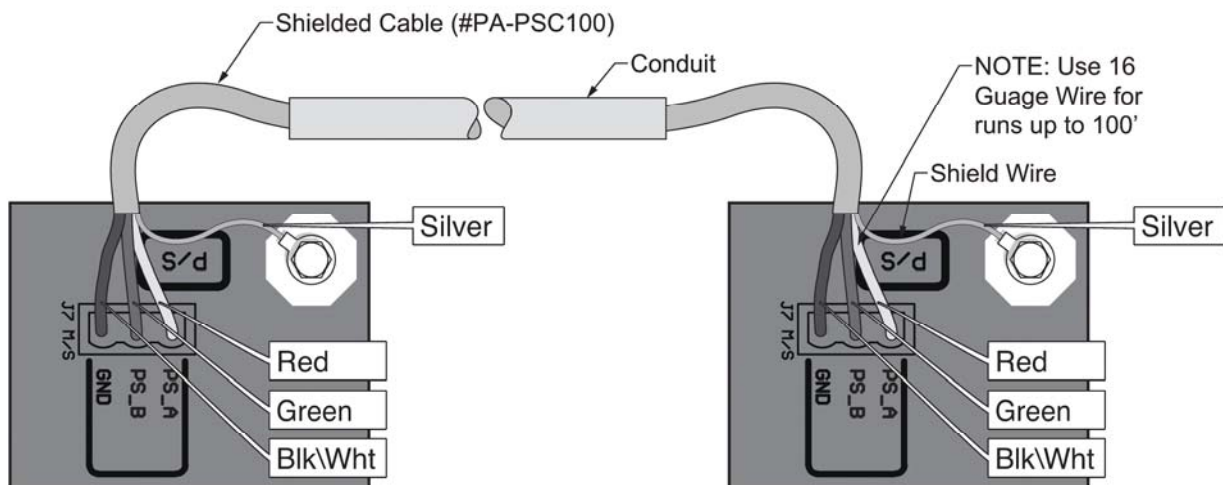

The control board provides a connector for Primary/Secondary connectivity. This connector will allow synchronized operation with a second gate operator.

NOTE: It is recommended to connected all external devices and set timer on the Primary unit. Timer setting on Secondary unit will be ignored.

All accessories must be connected to the primary operator.

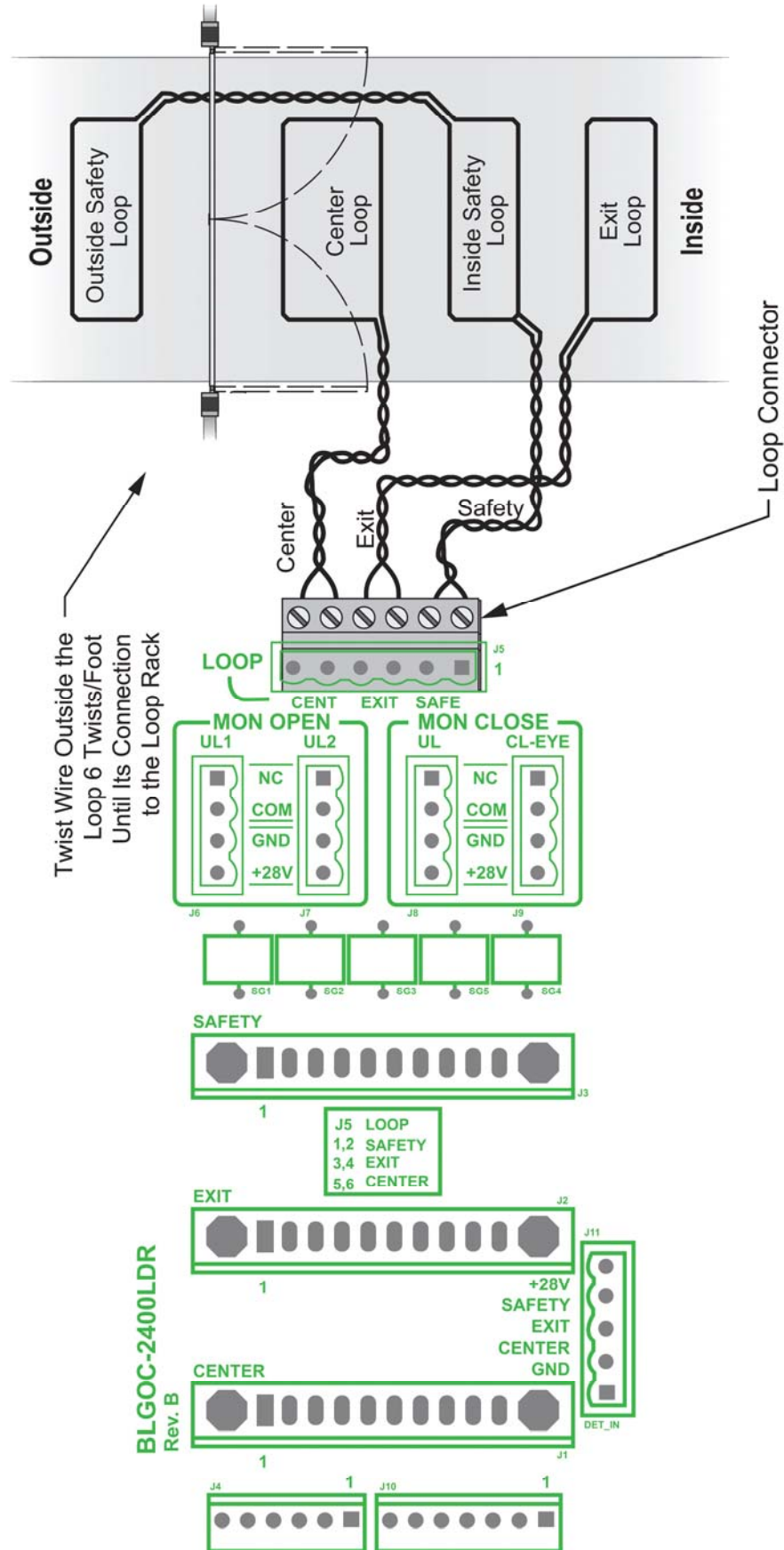

ACCESSORY CONNECTIONS

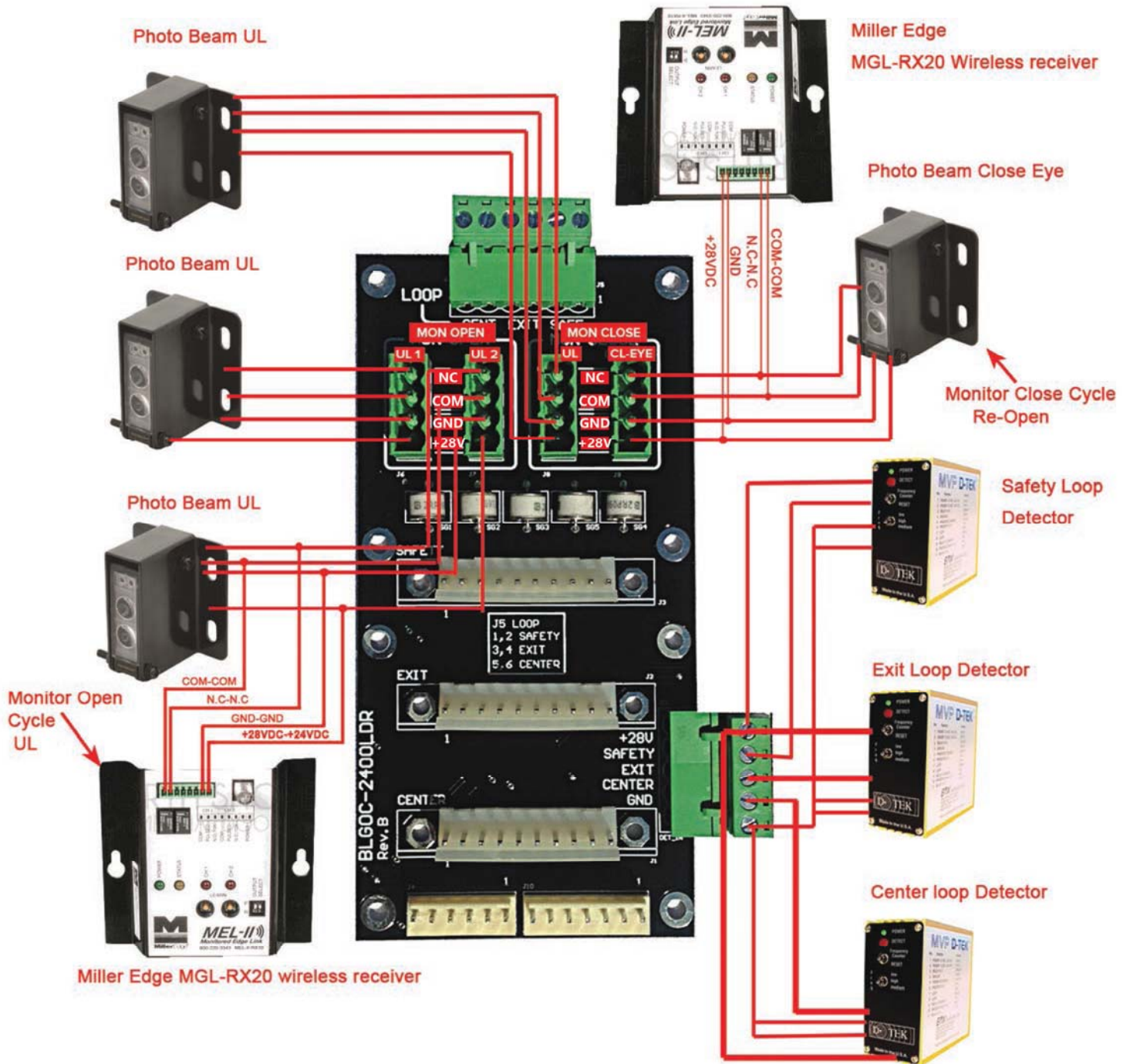

1. For the new UL 325 requirement, it needs minimum two external safety devices to monitor each operator. One monitors the open cycle, the other one monitors the close cycle. Maximum can install four safety devices.
2. A typical installation is to connect a photoeye sensor to the CL-EYE connector to monitor the close cycle, and install a contact sensor like the Miller Edge MGL-RX20 to the UL/UL2 connector at MON OPEN to monitor the open cycle.

ACCESSORY CONNECTIONS (Continued):

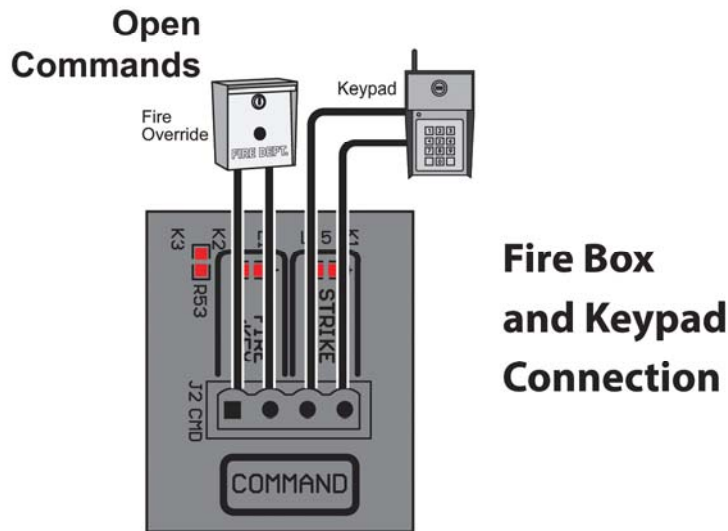

Radio Receiver

Need to verify the proper connections before connecting the Radio Receiver. The maximum voltage that the control board / battery can provide is about 28V for external accessories. If there is an electrical shot in the power to the accessories, the control board will protect itself by shutting down and will remain shut down until the short is fixed.

Two modes of operation that a radio receiver can control the gate:

Open-Close

By having the radio receiver connected as illustrated and with the Timer OFF: Every command of the radio transmitter will control the gate as follow:

- First command opens the gate
- Second command CLOSE the gate if at open position
- Third command OPEN the gate
- Any subsequent commands will continue in the same order to control the gate.

This type of configuration is not recommended for a commercial installations.

Open Only

By having the radio receiver connected as illustrated and with the Timer ON:

Each command of the radio transmitter is ALWAYS AN OPEN COMMAND to the gate.

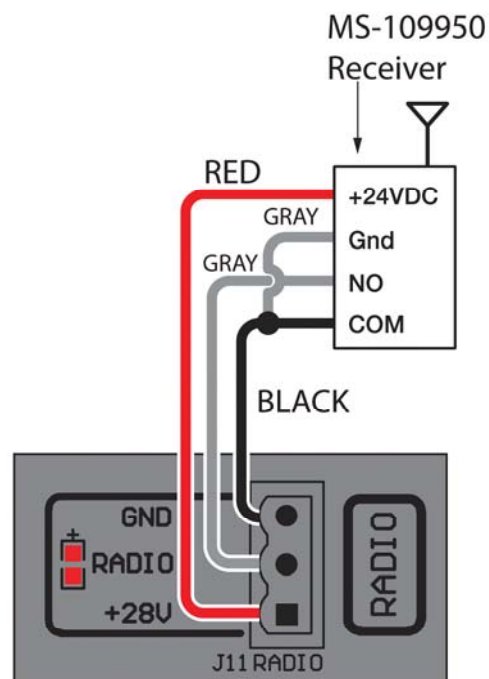

ACCESSORY CONNECTIONS (Continued):

Solenoid Connection

The solenoid power connection must be provided an external power source. This will prevent damage to the battery in the event of a line power failure.

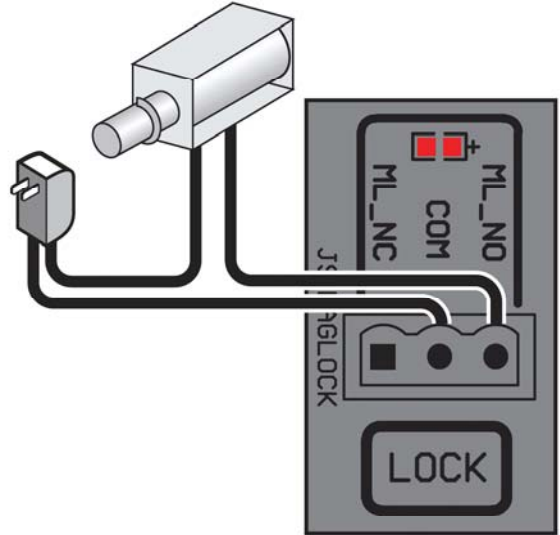

Guard Station

This will control the gate operator to Open, Stop, and Close the gate. The switches for Open and Close must be normally open type. The switch for Stop must be normally close type. They all can be using the same common ground. The control switch box should be within sight of the gate, out of reach of children, and away from moving parts of the gate.

If no guard station or STOP switch is installed, a jumper must be inserted between "STOP(NC)" and "GND" pins.

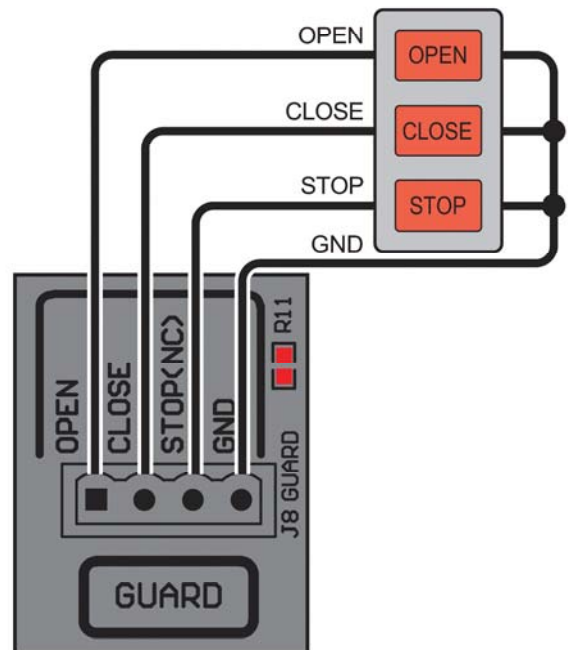

ACCESSORY CONNECTIONS (Continued):

Locks

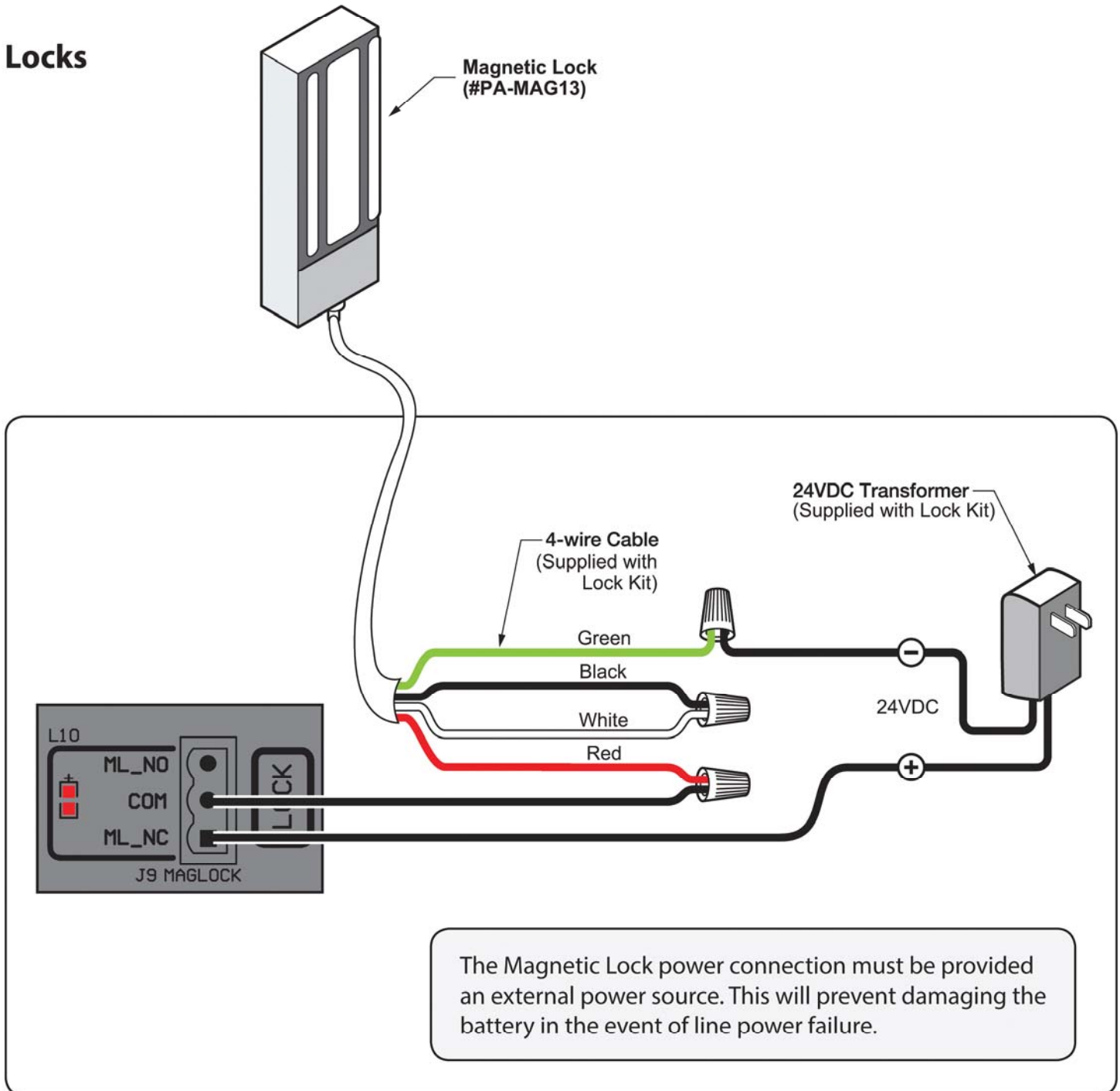

OPTIONAL ACCESSORY- part # (PA-MAG13).

PRIMARY/SECONDARY OPERATOR SELECT:

Primary/Secondary

To set the operator to Secondary: Select the DIP switch to SECONDARY position. Recycle power to make the new setting effective.

To set the operator to Primary: Select the DIP switch to PRIMARY position. Recycle power to make the new setting effective.

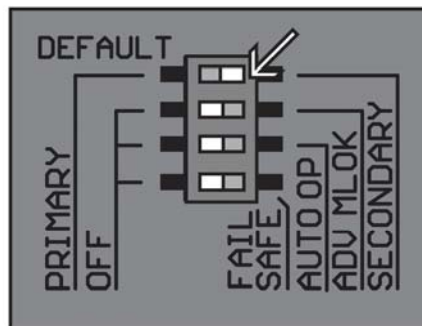

ADVANCING LOCK SELECT:

ADV MLOK

To set the maglock to be engaged before the gate reaches the close or open position: Select the DIP switch to ADV MLOK position.

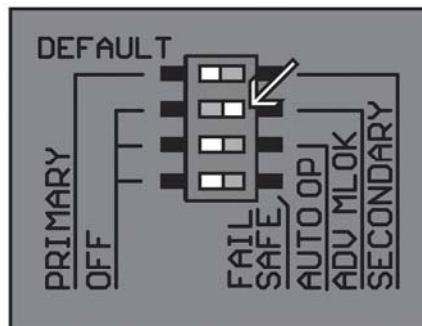

OPEN ON POWER FAIL:

The Auto-Open feature in Platinum Access Systems Gate Operators enables the following functionality in the event of power failure:

- Open the gate in case of power failure (120 or 220 VAC).
- Keep the gate at the open position as long as there is no power.
- Resume to normal operation when the power has been restored.

All accessories and safety devices are functional. The only function disabled is the close command.

Auto-Open

To enable the Auto-Open feature: Select the DIP switch to AUTO OP position.

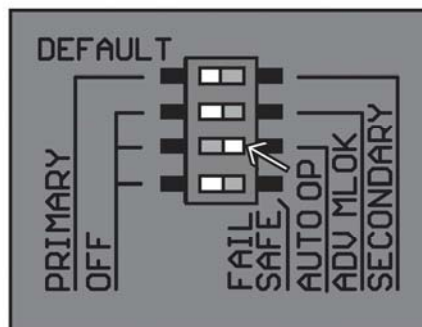

CLOSE TIMER:

Close Timer

Timer Feature when activated will close the gate automatically of a set number of seconds. This is adjustable from 3 to 60 seconds.

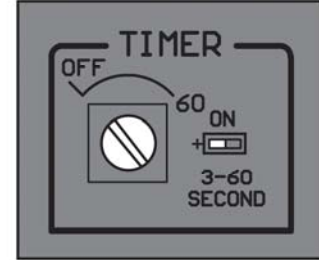

LEAF DELAY:

Leaf Delay

An Overlap Delay has been provided for biparting gates that have an emblem or maglock for example. It will provide up to a 3 second delay on primary or secondary operator.

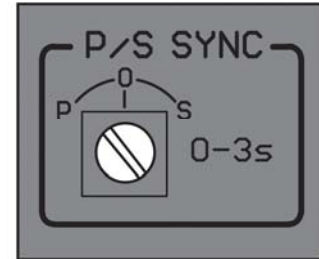

INSTANT REVERSING SENSOR:

Instant Reversing Sensor

The Obstruction Sensor needs to be adjusted to compensate for the installation and gate weight. The overload adjustment is provided to set the gate sensitivity.

- If the gate reverses by itself or stops in midcycle, it is too sensitive.
- If the gate hits an object and does not reverse or stop, it is not sensitive enough.
- Clockwise increases sensitivity, counterclockwise decreases sensitivity.

Test and adjust for proper reversing pressure

(Note: When unit alarms, push "STOP" or "RESET" button will clear the alarm)

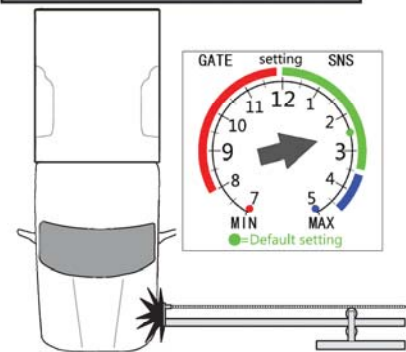
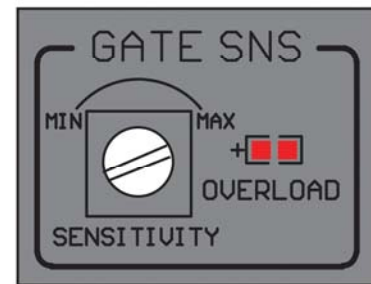

FAIL SAFE/SECURE:

Fail Safe/Secure

On = Fail Safe Off = Fail Secure

Fail/Safety	Battery Detection	AC Detection	Output
ON	Normal	Normal	Secure
ON	Normal	OFF	Fail Safe
ON	Low/OFF	Normal	Fail Safe
ON	Low/OFF	OFF	Fail Safe
OFF	Normal	Normal	Secure
OFF	Normal	OFF	Fail Secure
OFF	Low/OFF	Normal	Fail Secure
OFF	Low	OFF	Fail Secure

Note: When the output is "Fail Safe", there is less resistance to push the gate open manually.

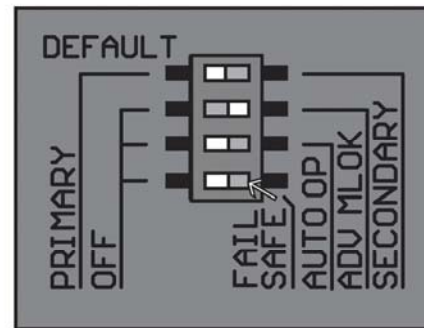

SOLAR INSTALLATION:

Step 1

A 24V solar panel or two 12V solar panels with minimum 80 watts capacity, Maximum Power Voltage (VPM) > 31V and Open Circuit Voltage (VOC) >38V is required.

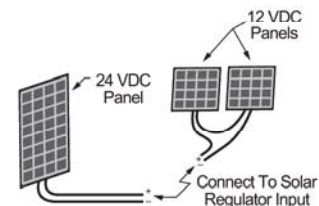

Step 2

Connect the solar panel cables to the Solar socket on the board.

Note: Please charged the operator batteries fully before installing the operator. If you use solar panel as the main power source.

Suggestion: You may need greater capacity for a jobsite. It depends on the following conditions:

1. The weight of the gate you may need batteries 14AH, 12V or greater capacity batteries if the gate is heavier than 400 lb.
2. The weather condition such a jobsite may has longer cloudy days.
3. The position of the gate such it's uphill/downhill gate.

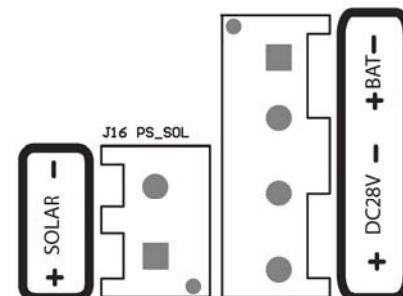

Optional Solar Installation: For Solar Panel controller installation, please call Technical Support.

- The gate system **MUST** be maintained. Have a qualified service person inspect, repair or adjust your system if any unusual behavior is observed or suspected.
- Severe or high cycle usage will require more frequent maintenance checks.
- Remove the Power Harness from the Control Board.
- Keep the gate area clean to insure proper operation.
- If not clean, servicing provides a good time to make it so, the operator should be cleaned up and the area around the operator should be clear of debris.
- Clean and lubricate the gate hinges. Make sure hinges are working smoothly.
- Check that all mounting hardware of the gate operator is properly tightened.
- Ensure that the gate moves freely.
- Check for corroded parts and replace if necessary.
- Check the battery for the following:
 - Battery connections must be free of corrosion.
 - Battery voltage must be 26 VDC minimum, (fully charged battery).
- Reconnect the Power Harness for the Control Board.
- Check and confirm the proper operation of all safety devices.
- Check and confirm the operation of all installed accessories.
- Check and confirm the operation of the manual release and selected features.
- Check the incoming line voltage and confirm it is within 10% of its rating (115 or 230 volts).
- Verify battery backup functionally by turning off the power source (115 VAC and 230 VAC). Don't forget to restore power after testing.

1. Motor Does Not Run

a. AC/SOL LED is OFF:

- Check battery breaker switch to make sure it is ON.
- Check the motor breaker to make sure it is turned to ON position.
- Make sure the AC Switch is ON and if necessary use a multi meter to check the input voltage to make sure it is 115VAC/220VAC.

b. AC/SOL LED is ON:

- Check the motor breaker to make sure it is turned to ON position.
- Check the motor wire connection to make sure every wire is firmly connected inside the terminal connector.
- Check limit switch wires to make sure the close limit switch wire is connected to Common/GND, and the other wire is connect to the normal close position.
- Disconnect all the external accessories first. Then check it to see if the motor can run. Some time the Photo beam sensor, edge sensor, loop detector, or other safety sensor prevents the motor from running.
- Turn OFF the AC switch, Turn OFF the battery breaker. Wait for 30 seconds. Then turn the battery breaker and AC switch ON. Then reset the operator(s). This is a hard reset.
- If you use the Multi Code 1090 receiver, please make sure the connection is correct. Connect from the receiver common pin to operator main board +28Vpin, and connect the receiver 24V pin to operator main board GND pin. If your connection is wrong, it can freeze the operator. Next turn the AC switch and battery breaker switch OFF. Wait for 30 seconds. Then turn these two switches back ON. Then reset the operator.

c. Power Failure:

- Check battery connection, and check each battery voltage (12VDC) to make sure the battery is still at good condition.

d. Overload Sensor and Alarm are ON:

- Press STOP button once to silence the alarm. Check the gate path to make sure everything is clear of obstructions. Double check to GATE SNS is set correctly. Normal SNS setting is at 2 O'clock. If needed, set sensor to 11 O'clock, 9 O'clock.

2. Problems While in Motion

a. Stops then Reverse:

- Please check the gate path to make sure the path is clear with obstructions.
- Double check the GATE SNS is set correctly. Normal setting is at 2 O'clock. If need, set sensor to 11 O'clock, 9 O'clock.
- Check the gate hinge, or wheels, or other hardware to make sure everything is working normally.
- Reset the gate operator to learn again.

b. Travel over the Limit Switch:

- Check the limit switch to make sure it is good.

-- Check the limit switch wire to make sure the connection is correct.

c. Does Not Close Automatically:

-- Check TIMER pot to make sure the setting is correct, or not. Normally set to 12 O'clock.

-- Check other external safe devices like Loop Detector, Photo Beam sensor, Edge Sensor, Radio to make sure none of them are activated.

3. Primary / Secondary Gate Configuration

a. Gates Open and/or Closes in Opposite Direction (Swing Gate).

-- Switch the OPEN DIR LEFT/RIGHT switch to the other direction.

b. Gates Do Not Close at the Same Time (Swing Gate).

-- Check the P/S SYNC pot to make sure it set to 12 O'clock. Then press reset button to reset the operators.

c. Gates Do Not Close in Preset Order (Swing Gates).

-- Check P/S SYNC pot to make sure the setting is correct. If it is correct, press rest button to reset the operators.

-- Check DIR switch to make sure one operator is set to secondary.

d. Sometime One Gate is Much Slower than the Other Gate.

-- Please make sure that every external device only connects to the Primary gate operator. Nothing should connect to Secondary gate operator. If any input device is connected to the Secondary unit, please change it to connect to the primary unit. Then press Reset to rest the operators.

e. Gates Hit Each Other (Master/Slave Slide Gates).

-- One gate over traveled. Make sure the limit nut has set correctly.

-- Please make sure the end user never use pad lock to lock the gates together. Only maglock can be used to lock the gates. Please correct this problem then reset the operators.

4. Others

a. Gate does not open at times and Alarm is ON (Swing Gate).

-- Please make sure the arm position in set up correctly. Make sure the arm does not put a lot of pressure on the output shaft when the gate starts to open.

b. Gate(s) Do not Open or Close and Alarm is ON.

-- Please make sure the There is a 4-pin terminal plug into the J8 GUARD connector with a short wire that short GND & ST

c. Operator Makes Beeping Sound.

-- Check battery. Battery voltage is low. Please make sure the battery breaker is ON, and the battery wire connection is good, and the charge led light is ON on the main board.

-- If these steps are OK and the unit is still making the beep sound, then it is time to replace the batteries. Please replace both batteries at the same time.

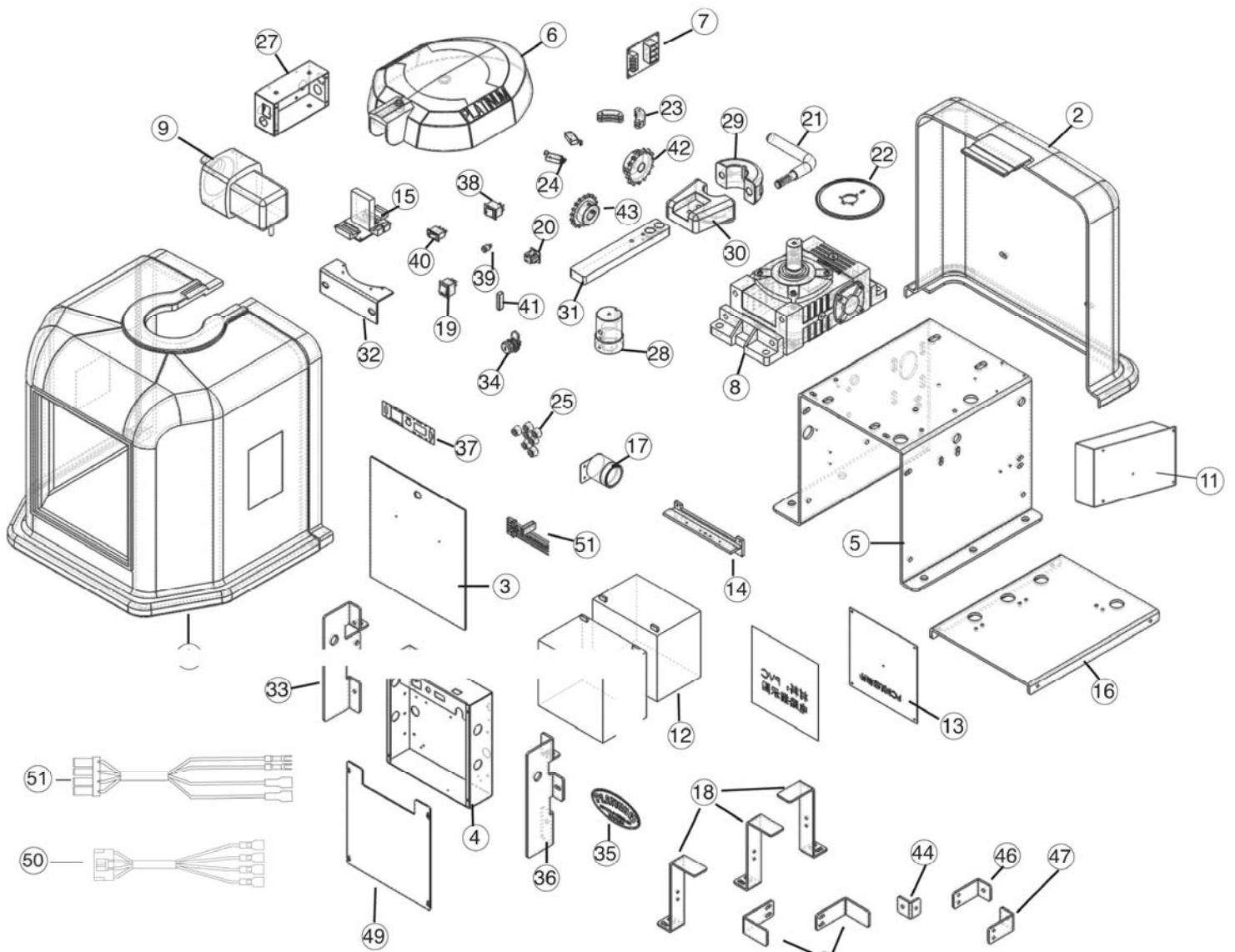

- 1. Front Cover
- 2. Rear Cover
- 3. Front Door
- 4. PCB Box
- 5. Chassis
- 6. Top Cover
- 7. EMI Boarder
- 8. Gear Box size 80
- 9. Brushless Gear Motor
- 10.
- 11. Switching Power Supply
- 12. 12V33AH Batteries
- 13. Main Board BLGOC-2400
- 14. Heatsink
- 15. Loop Board
- 16. Battery Base
- 17. Alarm
- 18. BAttery Bracket 2
- 19. AC Switch
- 20. AC Power Outlet
- 21. L Handle
- 22. Limit Cam Holder Plate
- 23. Limit Cam
- 24. Limit Switch
- 25. Rubber Feet
- 26. Battery Bracket 1
- 27. EMI Box
- 28. Output Shaft
- 29. Clutch Rear
- 30. Clutch Front
- 31. Clutch Arm
- 32. Limit Switch Holder
- 33. PCB Box Bracket Left
- 34. Lock
- 35. Platinum Logo
- 36. PCB Box Bracket Right
- 37. Switch Sticker
- 38. Motor Breaker
- 39. Reset Switch
- 40. Battery Breaker
- 41. Ouput Shaft keyway
- 42. Sprocket 40B30, Gear Box
- 43. Sprocket 40B12, Motor
- 44. PCB Box Right Bracket Holder
- 45.
- 46. Rear Cover Bracket, Left
- 47. Rear Cover Bracket, Right
- 48.
- 49. PCB Box Top Cover
- 50. Limit switch cable
- 51. Power Supply Cable

Field Wiring Diagram For BLGOC-2400 Board

Use twisted 2-pair shielded cable to connect the other operator to setup Primary/Secondary operation.

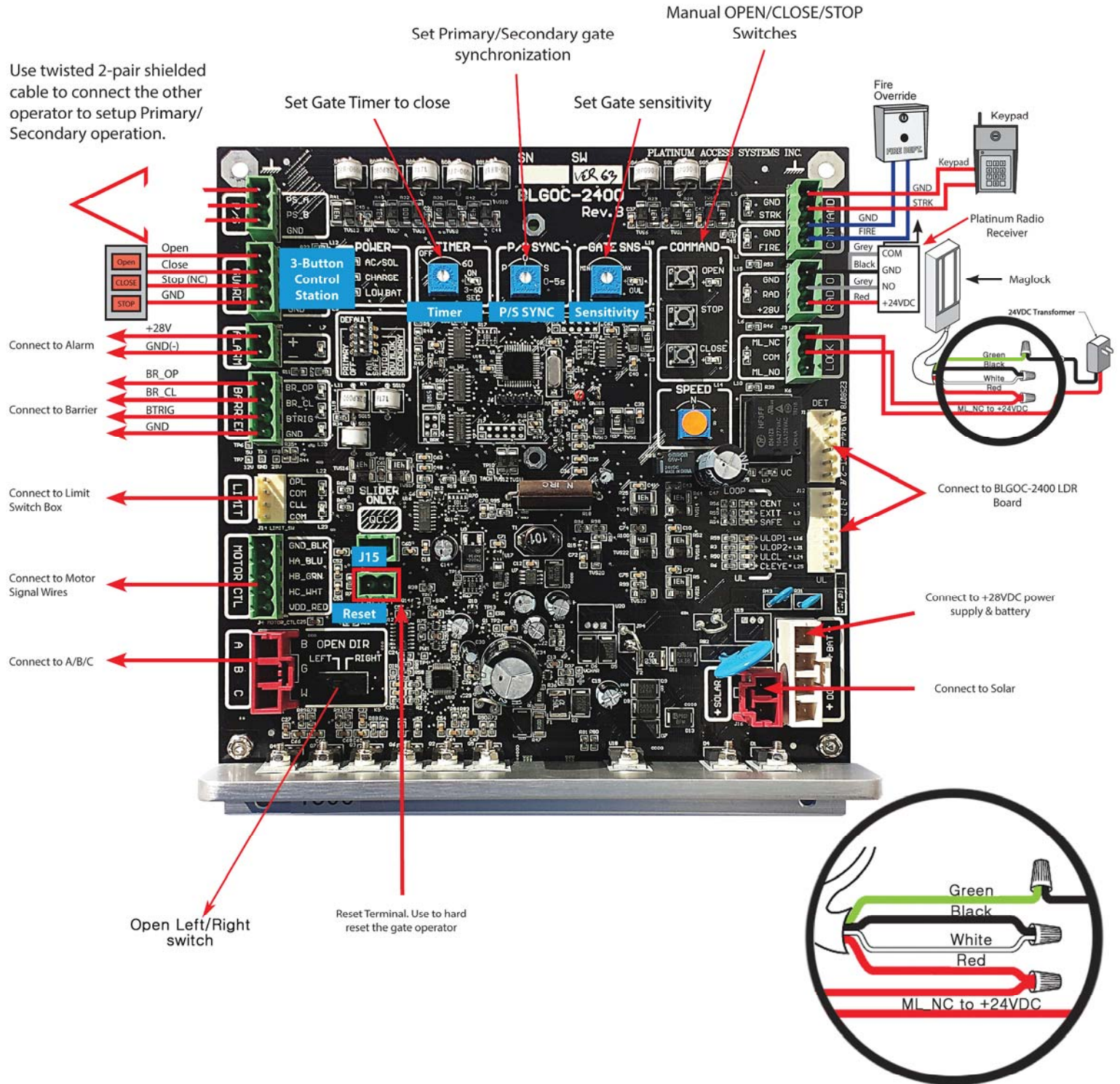

MON CLEYE

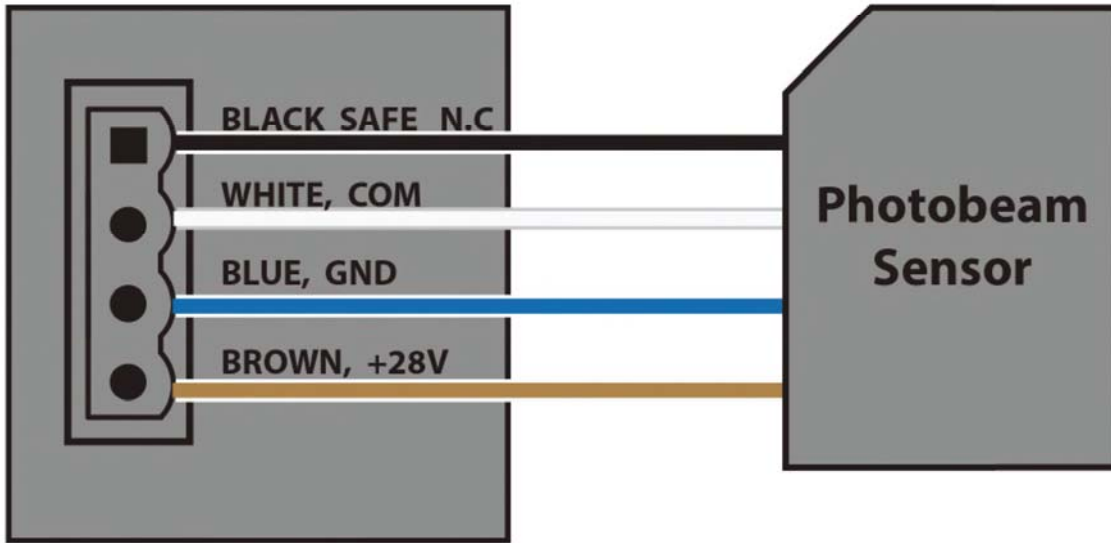

SECO-LARM	E936-S45RRGQ
EMX	NIR-50-325
EMX	NIR-50

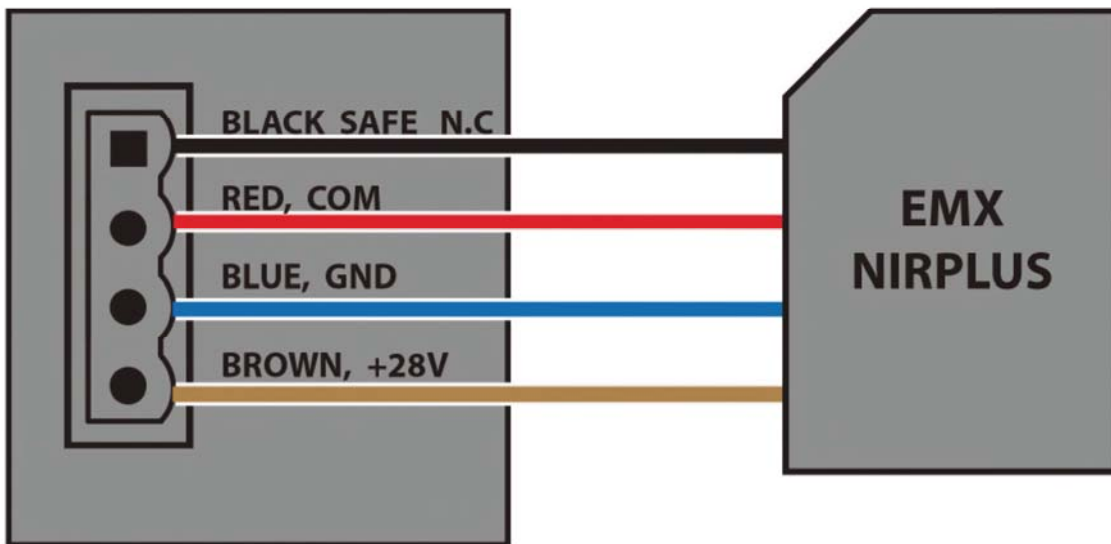

MONITOR OPEN

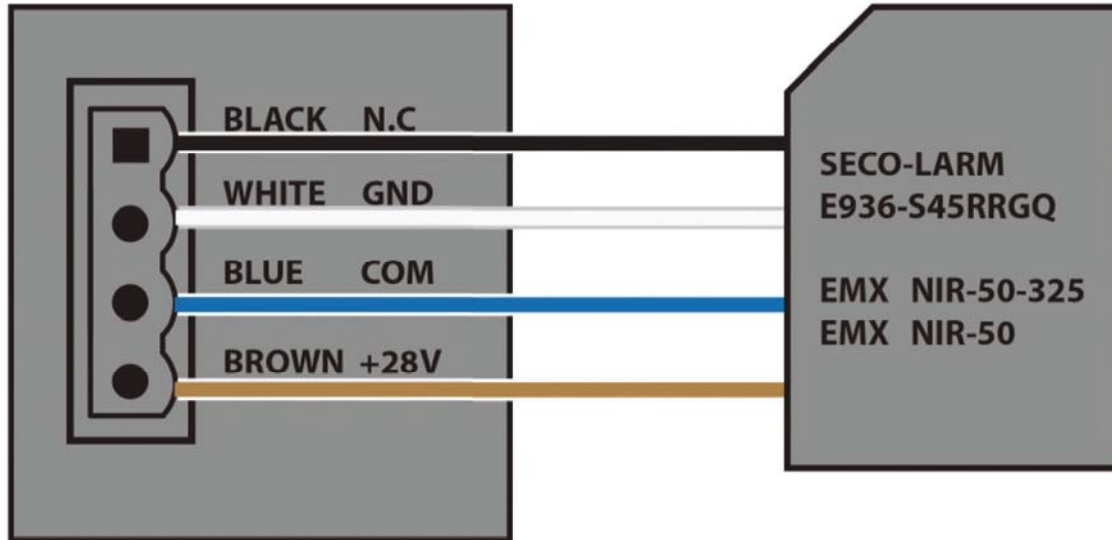

MONITOR CLOSE

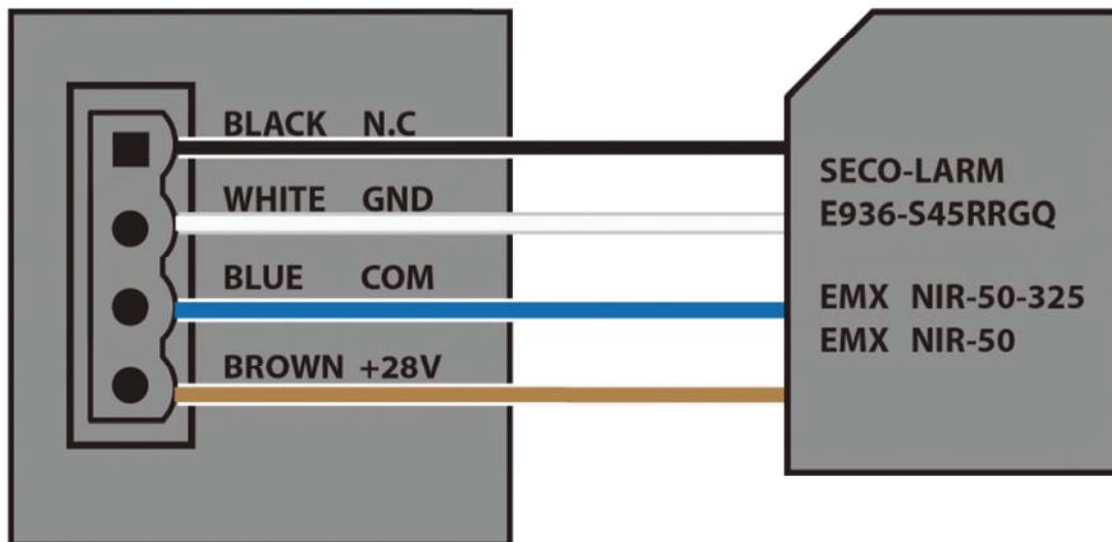

PLATINUM ETL APPROVED NON-CONTACT EXTERNAL SENSORS

Device Type	Mfg. Part#	Mfg. Name	Max Effective Range	ETL/UL325 Recognized	Notes
Reflector Photo Eye	NIR-50-325	EMX	MAX RANGE 50FT	Yes	
Reflector Photo Eye	NIR-50	EMX	MAX RANGE 50FT	Yes	
Reflector Photo Eye	IRB-RET	EMX	MAX RANGE 60FT	Yes	
Reflector Photo Eye	E-931-S50RRGQ	Seco Larm	MAX RANGE 50FT	Yes	
Thru-Beam Photo Eye Kit	E-936-S45RRGQ	Seco Larm	MAX RANGE 45FT	Yes	
Thru-Beam Photo Eye Kit	E-960-D90GQ	Seco Larm	MAX RANGE 90FT	Yes	
Thru-Beam Photo Eye Kit	IRB-MON	EMX	MAX RANGE 100FT	Yes	
Thru-Beam Photo Eye Kit	IRB-325	EMX	MAX RANGE 65FT	Yes	
Thru-Beam Photo Eye Kit	IR55	Albano Elettronica	MAX RANGE 55FT	Yes	
Thru-Beam Photo Eye Kit	42GRU-9001	Allen Bradley	MAX RANGE 30FT	Yes	N.O means N.C Platinum Board
Thru-Beam Photo Eye Kit	Prime-Guard	Miller Edge	MAX RANGE 50FT	Yes	

PLATINUM ETL APPROVED CONTACT EXTERNAL SENSORS

Device Type	Mfg. Part#	Mfg. Name	Description	ETL/UL325 Recognized	Notes
Wireless Edge Link	MGL-K20	Miller Edge	Come with Transmitter & Receiver	Yes	
Wireless Edge Link	MGL-RX20	Miller Edge	Receiver	Yes	

TOP VIEW OF THE SWING OPERATOR

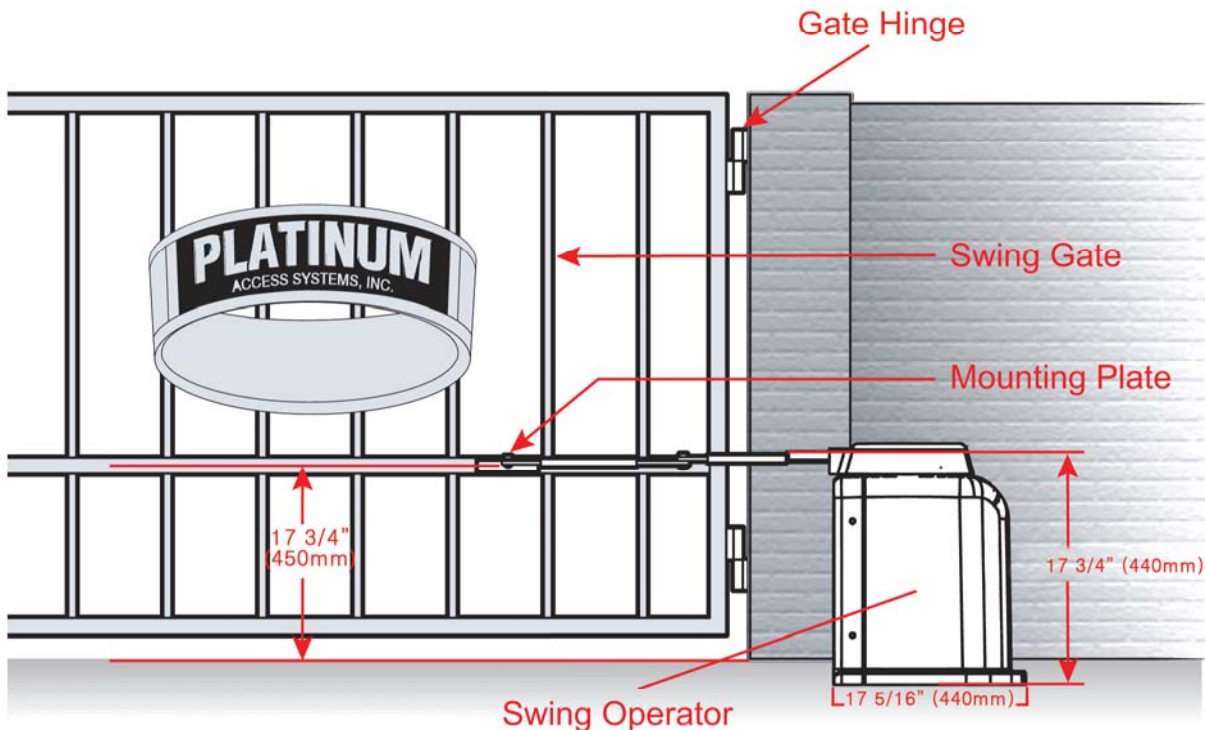
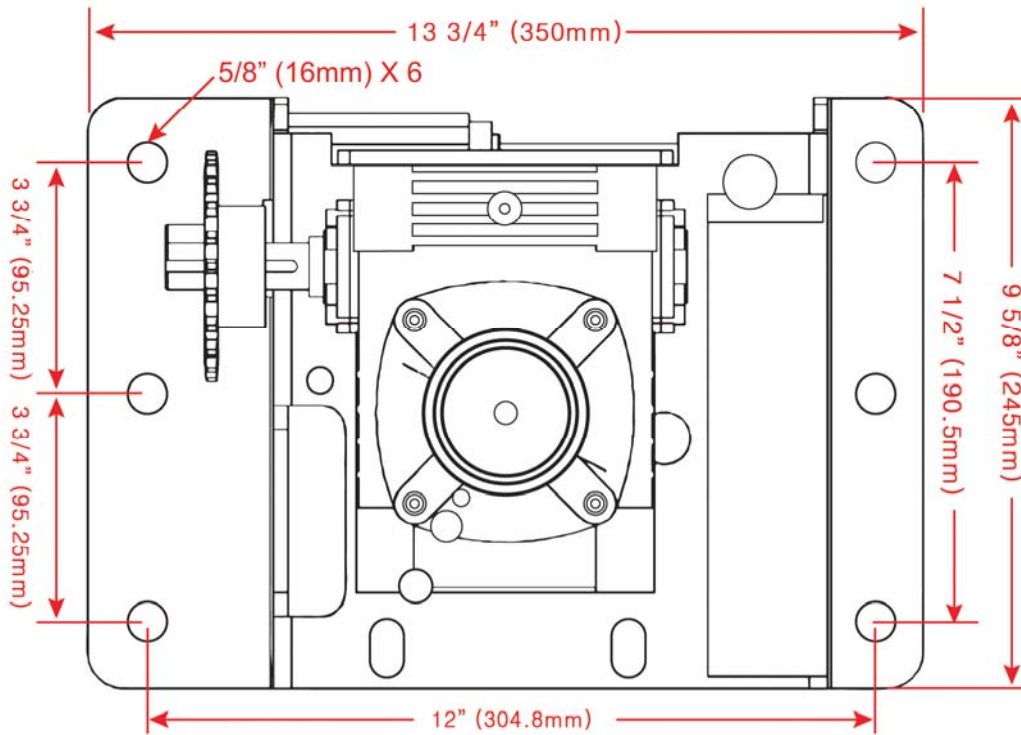

Swing Operator Arm Mounting Plate Location

TOP VIEW OF THE SWING OPERATOR

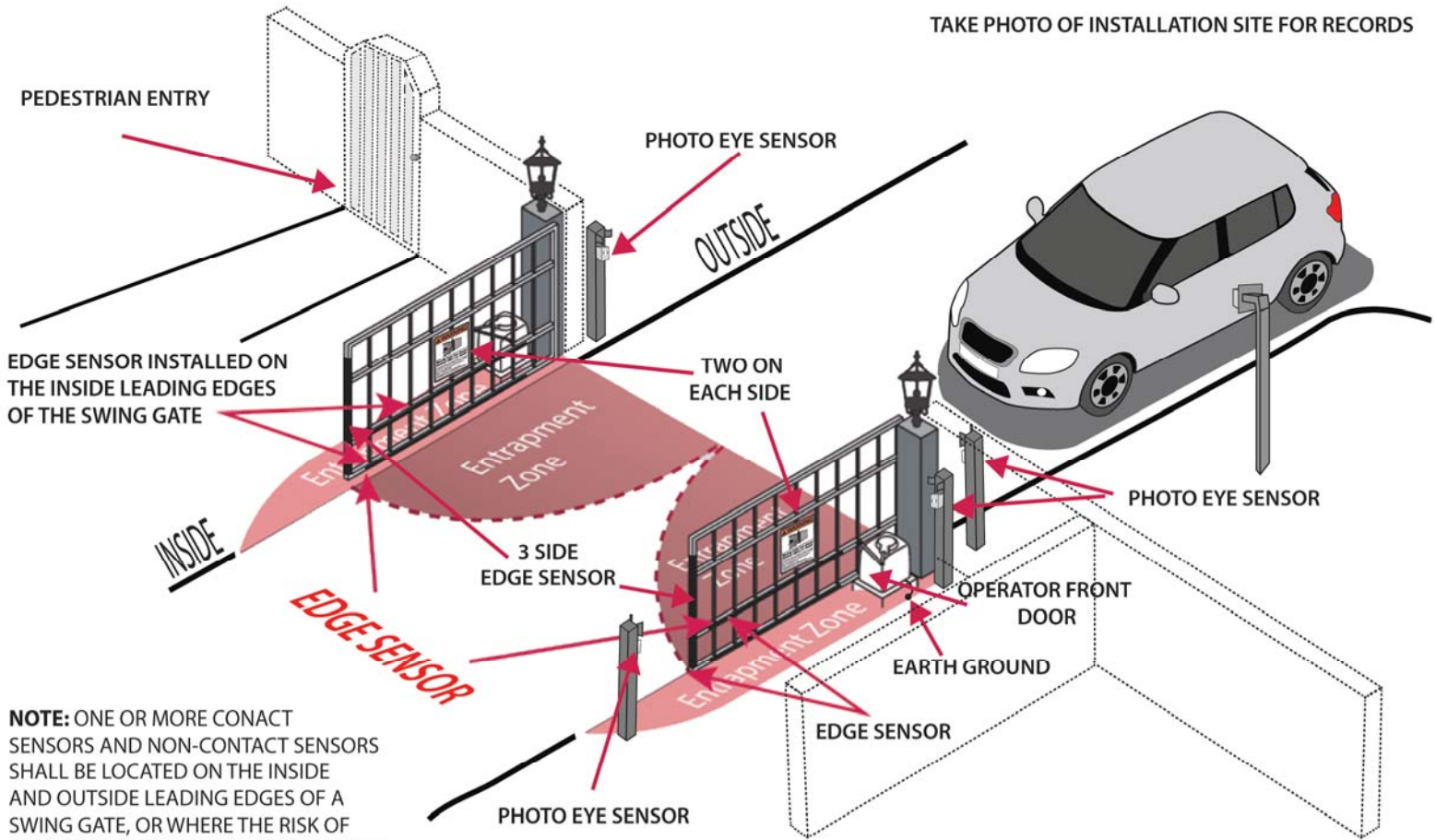

TAKE PHOTO OF INSTALLATION SITE FOR RECORDS

NOTE: ONE OR MORE CONTACT SENSORS AND NON-CONTACT SENSORS SHALL BE LOCATED ON THE INSIDE AND OUTSIDE LEADING EDGES OF A SWING GATE, OR WHERE THE RISK OF ENTRAPMENT, OR OBSTRUCTION EXISTS, SUCH AS THE PERIMETER REACHABLE BY A MOVING GATE, OR BARRIER

THIS IS FOR EXAMPLE ONLY. YOUR SITE MAY NEED TO INSTALL MORE SAFETY DEVICES TO PROTECT EVERY ENTRAPMENT ZONE

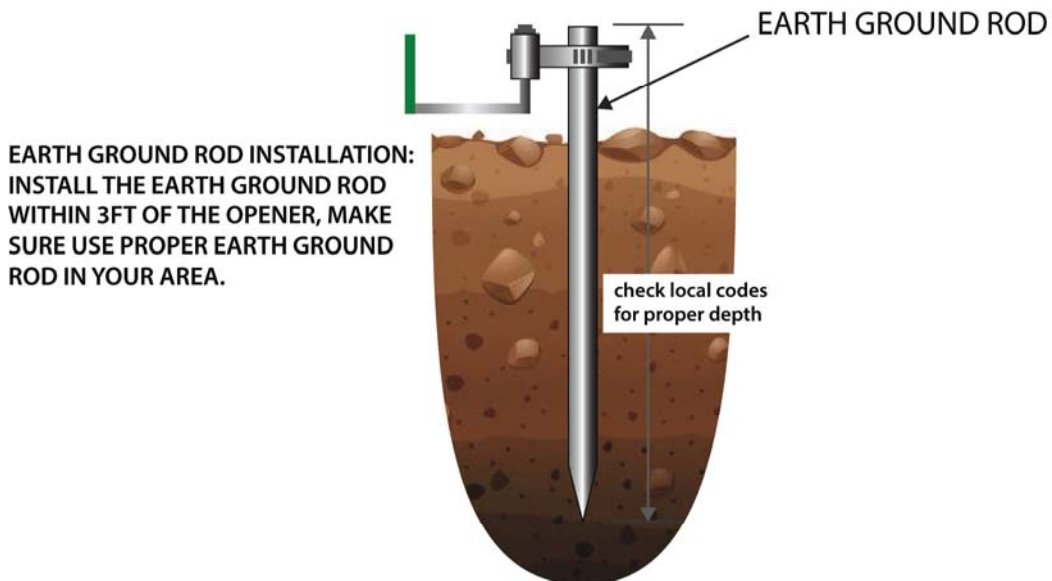

STANDARD WING ARM INSTALATION POSITION WHEN GATE IS FULLY CLOSED

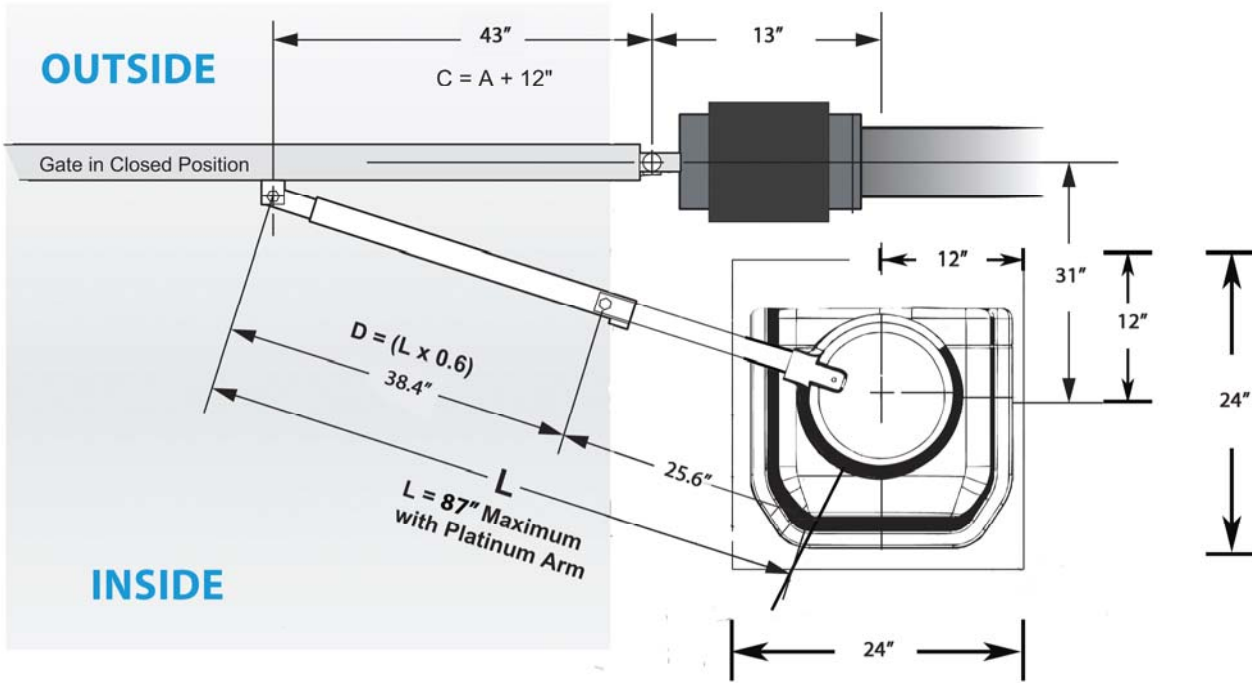

STANDARD WING ARM INSTALATION POSITION WHEN GATE IS FULLY OPENED

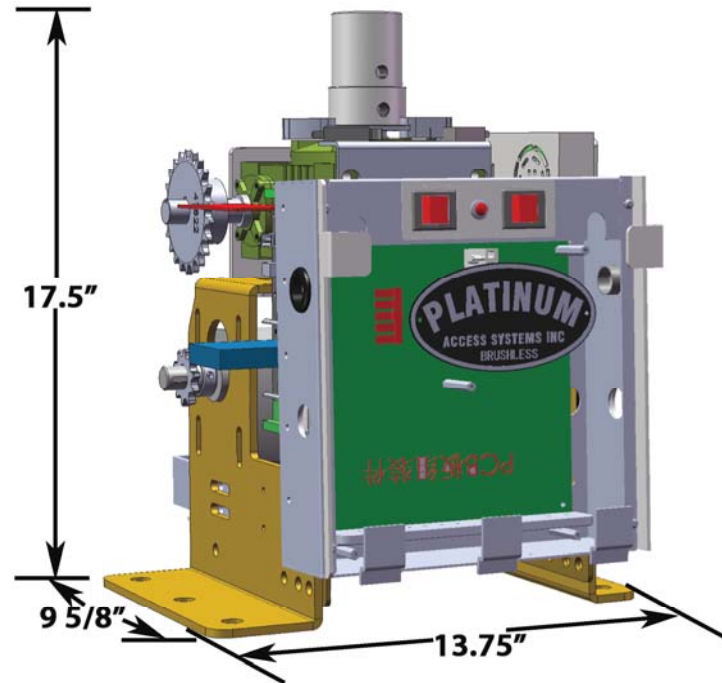
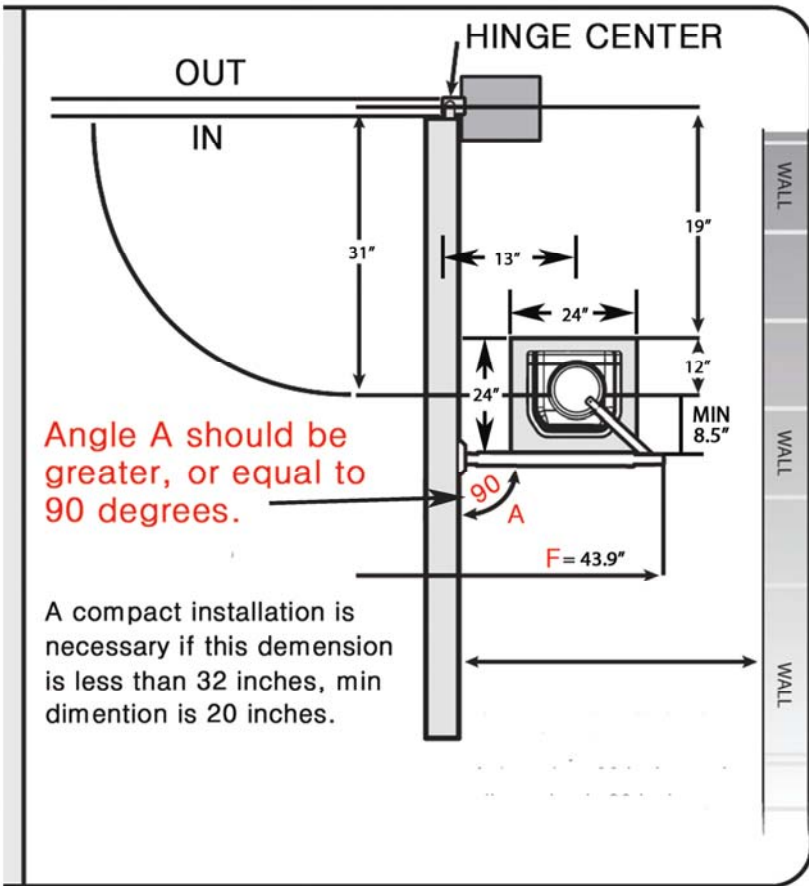

PLATINUM RECEIVER PL-JS-181 INSTALLATION:

1. Connect two blue wires to the RESET, J15, 2-Pin green connector on the board if apply.
2. Connect Red, Black, and two Grey wires to RADIO J11 in the following way:
 - Connect Red wire to +28V
 - Connect one Grey wire to RAD
 - Connect Black wire and the other Grey wire to GND.

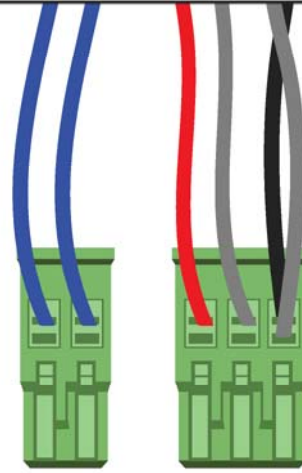

Receiver Wire Connection Picture 1

PROGRAMMING THE PL-JS-181 RECEIVER TO WORK WITH THE PL-RC-C1 TRANSMITTER:

1. Open the Receiver by taking off the screw on the bottom side of the receiver.
2. Press down and then release the K1 tactile switch which located at the corner that near the silver crystal in the receiver. The LED will turn in green. Then press down and hold button #1 on the Platinum Transmitter PL-RC-C1 for 3 seconds.
3. The Receiver LED will be flashing once it has learned the Transmitter code successfully.
4. Wait for about 5 seconds. Then press button #1 on the Transmitter to confirm the transmitter works with the receiver. If not, then repeat step 2 to step 4 to make it works.
5. Repeat step 2 to step 3 to program the other three transmitter buttons if need.

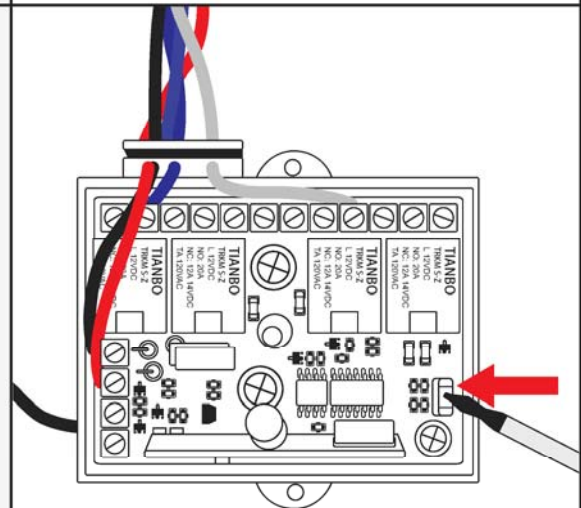

Location of the Tactile Switch in the PL-JS-181 Receiver

PROCEDURE TO MAKE THE TRANSMITTER PL-CRC-I11 TO COPY THE TRANSMITTER PL-RC-C1 CODE:

1. Press down both buttons in the same time on the PL-CRC-I11 transmitter and hold it till the blue LED flashing for 3 seconds (It takes about 13 seconds totally).
2. Next bring both transmitters PL-RC-C1 and PL-CRC-I11 close to each other. Make sure the transmitter PL-RC-C1 antenna is touching the transmitter PL-CRC-I11 top surface.
3. Press down PL-CRC-I11 transmitter "A" button and hold it. Then press down the PL-RC-C1 #1 button. The PL-CRC-I11 blue LED will flash a few times once it has learned the code successfully.
4. Repeat step 2 to Step 3 to make the PL-CRC-I11 button "B" to learn the #2,#3, or #4 button code from the PL-RC-C1 transmitter.

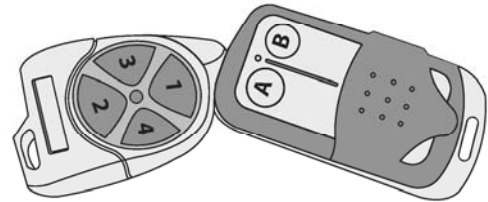

**PL-RC-C1
Transmitter**

**PL-CRC-I11
Transmitter**

Picture shown the position of the transmitters when using transmitter PL-CRC-I11 to copy the code from transmitter PL-RC-C1

PROCEDURE TO ERASE THE TRANSMITTER PL-CRC-I11 CODE :

1. Press and hold both button A & button B down until the blue LED flashing for 3 seconds. Normally it takes about 10 seconds.



WARNING: to reduce the risk of injury or death:

Photoeye Sensor Alignment Installation Instruction For Revision-166, Or Later Firmware For BLGOC-2400 Main Board

1. Turn off AC and Battery power.
2. Take out the 4-pin terminal jumper from the GUARD terminal.
3. Connect the first photoeye sensor to the CL-EYE terminal on the BLGOC-2400LDR Loop board.
4. Look for a good location to secure the Photoeye sensor receiver.
5. Turn battery power ON.
6. Now you hear one alarm sound every 5 seconds.
7. Next try to align the lens to the photoeye sensor receiver. If the lens is aligned to the receiver, then you hear the alarm sound rapidly (6 alarm sounds per second).
8. Once you approximately have located the area to put the lens. Next you need to move the lens left and right, up and down to center the lens.
9. Once you have centered the lens. You can secure the lens.
10. Disconnect the photo eye sensor receiver from CL-EYE terminal. Use the same method start from step 1 to align the photo eye sensor lens for UL1 at the MON OPEN terminal.
11. If you only install two photo eye sensors(One monitors the gate close cycle, and the other one monitors the gate open cycle). Then you can go to step 14. Otherwise go to step 12.
12. Use the same method to align the other photo eye sensors for UL2 at the MON OPEN terminals.
13. Use the same method to align the other photo eye sensors for UL terminals if need.
14. Once you have completely aligned all the photo eye sensors. Put the 4-Pin terminal jumper back to Guard terminal. And plus in all the photo eye sensors receivers(One must connects to the MON-EYE terminal, and other one connects to one of the UL1, or UL2 terminal at MON OPEN). Then reset the operator.

Note: To check the lens to see if the lens is at the center position to the receiver, or not, you can make a 1.5" in diameter circle from a piece of cardboard. And use this cardboard to cover the lens with the center of the circle aligns to the center of the lens. Then use a transmitter to open/close the gate to see if the gate still work. If the gate is still working, that mean the lens is at the center position to the receiver, if not, go back to step 1 to align the lens correctly.

FIGURE 2

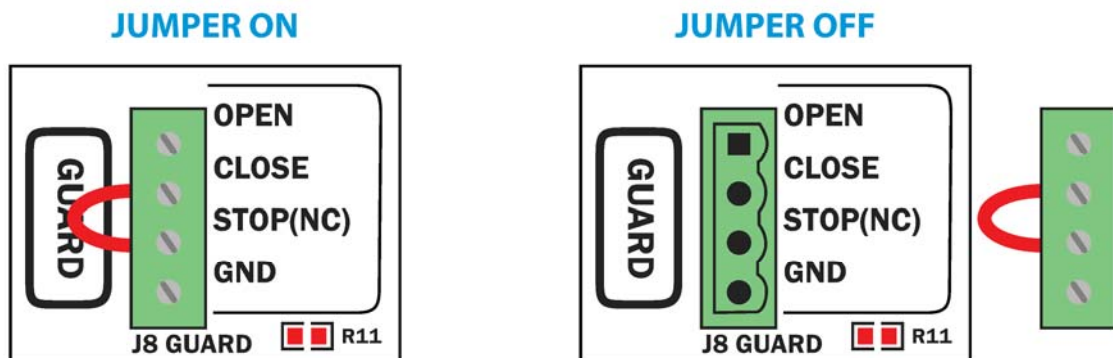



PLATINUM ACCESS SYSTEMS™

1725 E. Grevillea Court, Ontario, CA 91761
Phone: (909) 259-6000 | Fax: (909) 923-7890

www.PlatinumASI.com

© 2019 Platinum Access Systems, Inc. All Rights Reserved.