

REVISIONS

REV	DESCRIPTION	DRW	APPR
C	Added Items 2,75,77,91,180,195,197,199. Revised Qty Items 108,161,179 Was: 3,17,15.	Scf 01/23/09	D.C. 01/23/09

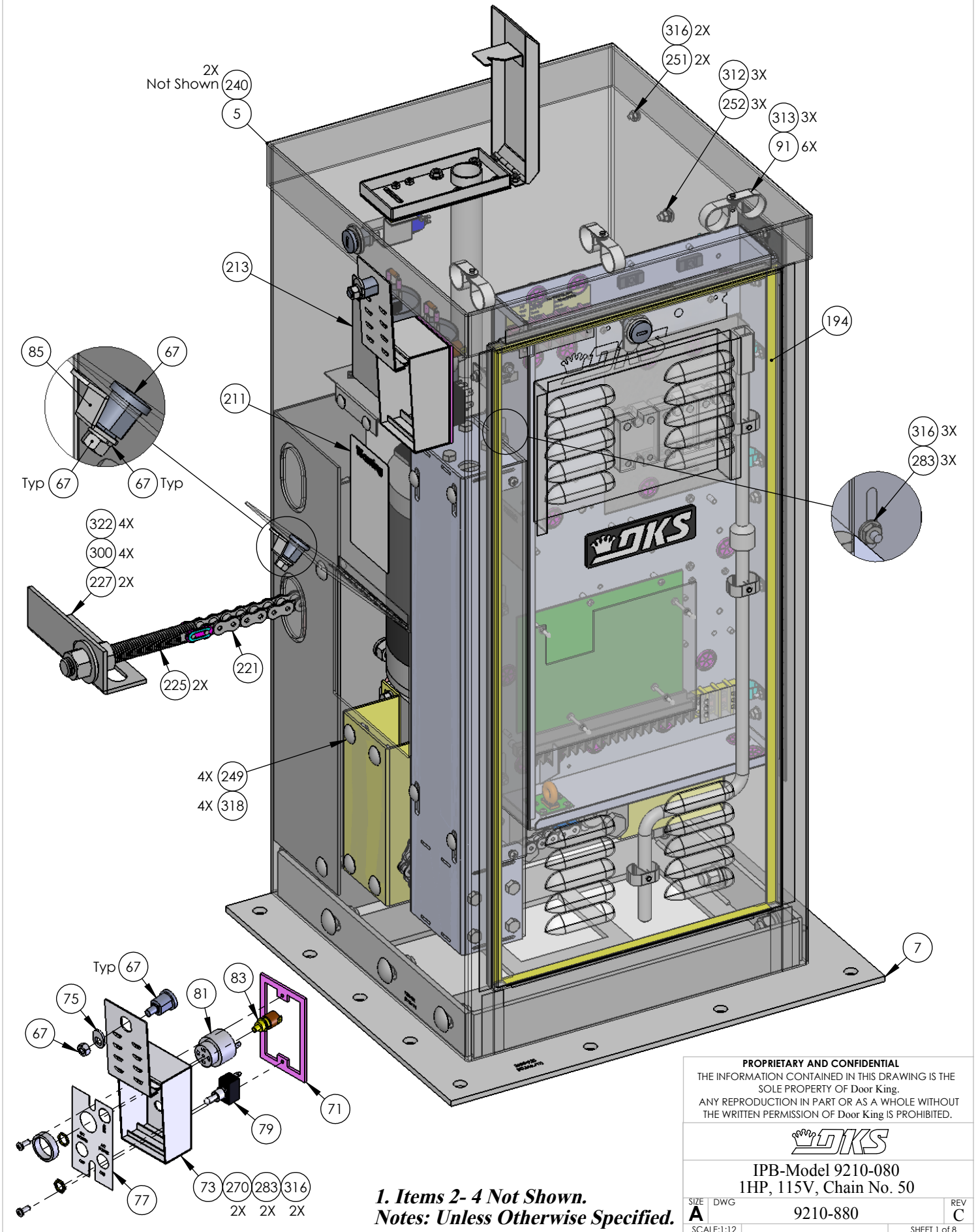

DETAIL A
SCALE 1 : 4

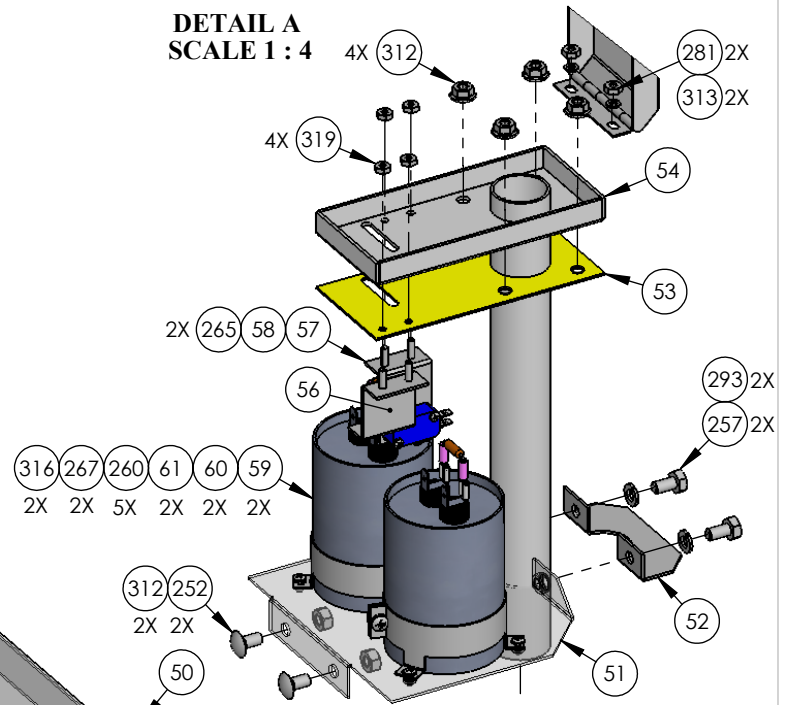

DETAIL B
SCALE 1 : 4

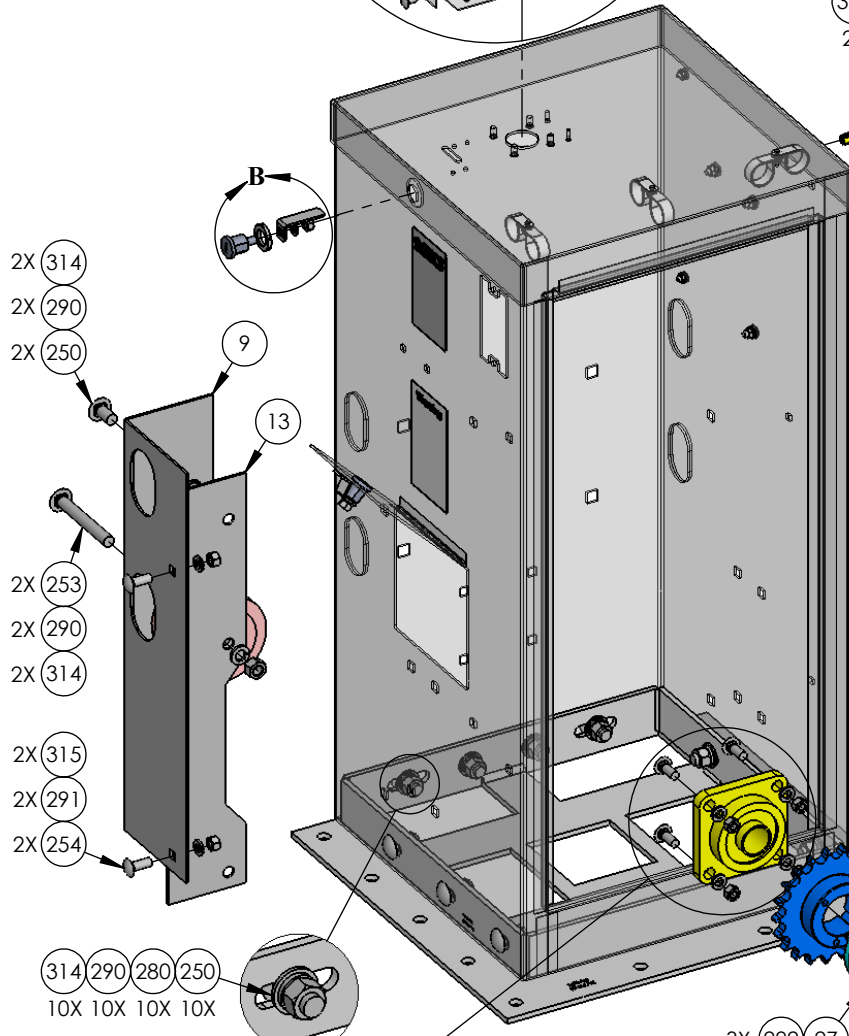
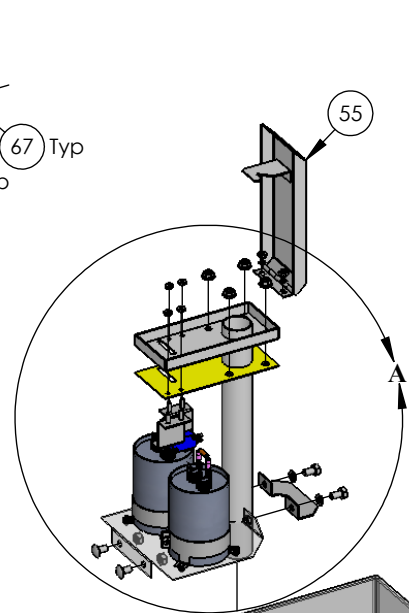

DETAIL C
SCALE 1 : 3

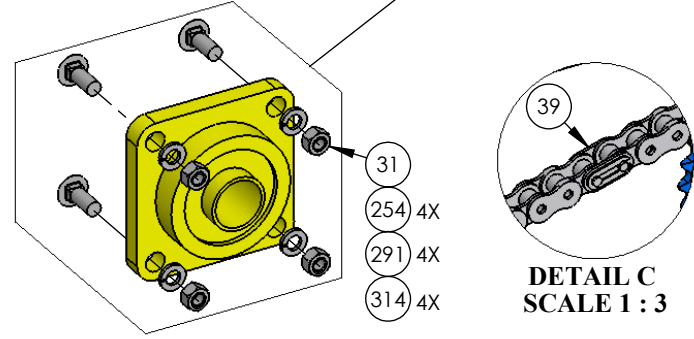

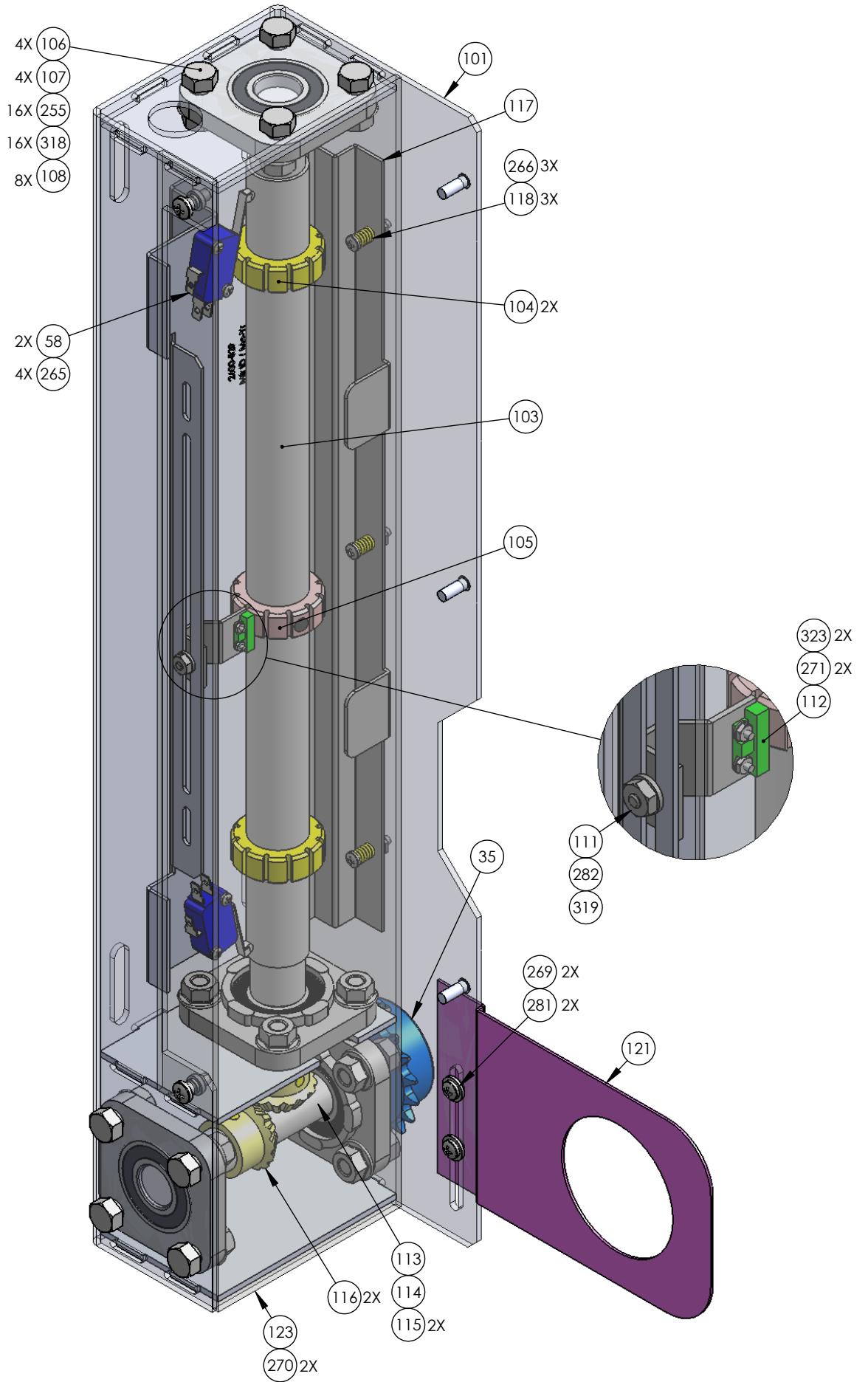

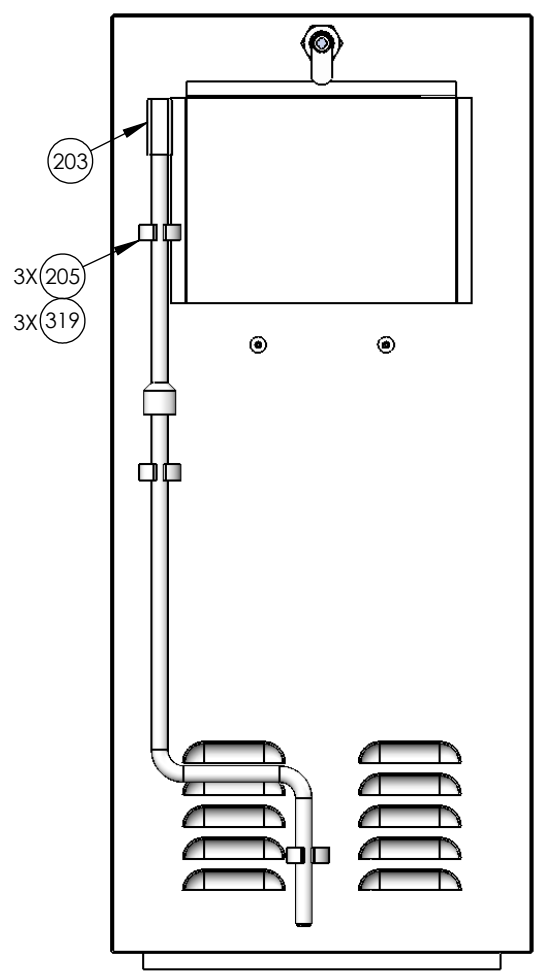
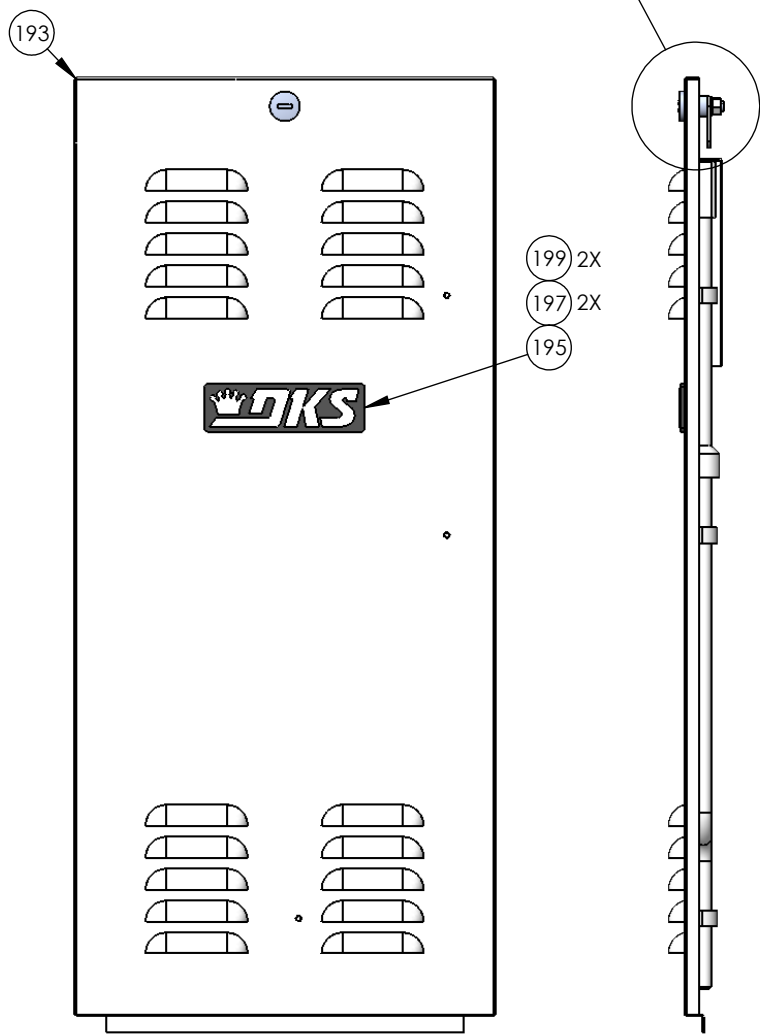
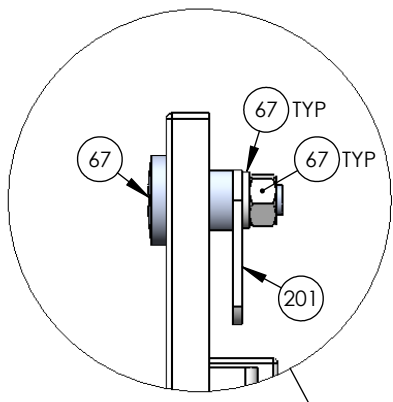
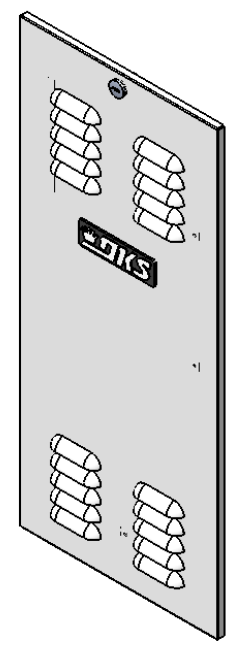

Item	Part Number	Qty	UM	Description	Rev
1	9210-880	1	EA	IBP-Slide Gate Operator 1HP 115V	C
2	9210-065	1	EA	Manual for Model 9210	
3	9210-143	1	EA	Wire Set 9210 Sngle Phase	
4	9210-044	1	EA	Wire Harness 9210 Subassy SSR	
5	9200-905	1	EA	Housing-9210-9240	
7	2600-920	1	EA	Baseplate 920	
9	2600-919	1	EA	Bracket Idler Left Model 920	
11	2600-918	1	EA	Bracket Idler Right Model 920	
13	2600-923	1	EA	Bracket Idler Left Model 920	
15	2600-924	1	EA	Bracket Idler Right Model 920	
17	2600-335	2	EA	Idler Bushing 9200	
19	2600-394	2	EA	Idler Wheel UHMW Model 9200	
21	2600-971	1	EA	Bracket Gear Box Left Mod 920	
23	2600-972	1	EA	Bracket Gear Box Right Mod 920	
25	2600-348	1	EA	Gearbox Model 920/9200	
27	2600-356	1	EA	Sprocket Hub for 920 P1x1 1/4"	
29	2600-395	1	EA	Sprocket H50P25 50 Chain	
31	1200-010	1	EA	Hinge Bearing	
33	2600-317	1	EA	Sprocket 25 th 1 1/4" Bore #35	
35	2600-316	1	EA	Sprocket 19 th 3/4" Bore #35	
37	9200-421	1	EA	Chain #35 21" 56 Links Length	
39	2600-479	1	EA	Chain Master Link #35	
41	2600-278	1	EA	Motor 1HP CFce PSC 1725 115V1P	
50	2600-880	1	EA	Hole Plug Plastic for 3/8 Hole	
51	2600-571	1	EA	Bracket Crank Tube Supp 9200	
52	2600-572	1	EA	Bracket Crank Tube 9200	
53	2600-729	1	EA	Gasket 9200 Hand Crank	
54	2600-570	1	EA	Bracket Crank Tube Frame 9200	
55	2600-525	1	EA	Bracket Crank Tube Cover 9200	
56	2600-526	1	EA	Bracket Cam Stop 9200	
57	2600-527	1	EA	Bracket Limit Switch 9200	
58	1804-024	3	EA	Switch Micro No NC C	
59	2600-875	2	EA	Capacitor Mounting Clamp	
60	2600-102	2	EA	Capacitor 50uf 370VAC	
61	9210-197	2	EA	Resistor Assembly Bleeder 22k	
67	4001-035	4	EA	Lock N16058BDxSFx2K Key 16120	
69	1702-509	1	EA	Bracket Lock Cam 9200	
71	2600-731	1	EA	Gasket Switch Cover	
73	2600-533	1	EA	Switch Cover Doorcking Lockable	
75	1702-501	1	EA	Cam 7/8"	
77	2599-051	1	EA	Label - Mylar 9000 Series Oper	
79	1601-041	1	EA	Switch Toggle SPST 2POS	
81	1506-071	1	EA	Tone Generator Loud	
83	1812-005	1	EA	Switch Push Button N.O.	
85	1702-515	1	EA	Cam Offset	
91	2600-639	6	EA	Wire Clamp-1"	
101	2600-529	1	EA	Bracket Limit Enclosure 9200	
103	2600-909	1	EA	Shaft Limit Threaded 9200	
104	2600-246	2	EA	Limit Nut	
105	2600-248	1	EA	Limit Nut w Magnet Assembly	
106	2600-454	4	EA	Bearing Holder Plastic Front	
107	2600-440	4	EA	Bearing Used in Slide Oper	

108	2600-096	8	EA	Washer SS 1.125"ODx.75"IDx.03"
111	9210-303	1	EA	Bracket Partial Open Limit
112	1601-256	1	EA	Switch Magnetic Sensor
113	2600-199	1	EA	Shaft Limit Cross 9200
114	2630-018	1	EA	Snap Ring 3/4" 01121
115	2600-032	2	EA	Spirol Pin - 3/16" D x 1" L SS
116	2600-309	2	EA	Gear Bevel 15 tooth Bored 3/4"
117	2600-522	1	EA	Bracket Limit Hold 9200
118	2600-857	3	EA	Spring-Compression Limits
121	2600-241	1	EA	Chain Guard 9200
123	9200-005	1	EA	Cover Plastic Limits
133	9200-900	1	EA	Mount Plate PCB Hinged 9200
135	9200-913	1	EA	Mount Panel PCB 9200
136	9210-006	1	EA	Cover Plastic
137	9200-925	1	EA	Mount Plate Solid State Relays
139	9200-932	3	EA	Solid Ste Rely 1P SGD2544RD3
143	2600-945	1	EA	Cover Plastic Insulator
145	1200-028	2	EA	Outlet Snap-In Leviton 1306
147	2600-749	8	EA	Wire Connector STA-KON RC6
149	2600-431	1	EA	Marker Strip Silkscreened 910
151	3130-008	1	EA	Terminal Block 5 pin
153	3129-005	1	EA	Terminal Block Cover 5 Positio
155	2600-439	1	EA	Washer Cup - Brass
157	2599-006	1	EA	Decal SUPPLY GND
158	2599-014	1	EA	Decal Copper Wire Only
159	2599-008	1	EA	Label Patent
161	2600-810	19	EA	Bushing 7/8 Poke Thru Flaps
163	4404-010	1	EA	PCB Gate Operator
167	4001-020	1	EA	Terminal 20 Pin
169	4001-021	1	EA	Key Polarizing Tyco 1437410-5
170	9200-234	1	EA	Bracket High/Low Volt Separatr
171	2343-010	1	EA	PCB Current Sensor
175	2600-414	1	EA	Terminal Block-2 Position
177	3129-002	1	EA	Terminal Block Cover 2 Positio
179	2600-619	14	EA	Wire Clip-5/8" Concord 770-1209
180	1804-029	3	EA	Mount Wire Tie
184	1804-031	18	EA	Tie Wrap 4"
193	9240-927	1	EA	Door Model 9210 Stainless
194	4001-018	7	FT	Weather Stripping 50' rolls
195	2600-732	1	EA	Nameplate Plastic DKS
197	1897-052	2	EA	Gasket, Microphone Support
199	2802-040	2	EA	Washer Push on Clamp
201	1702-503	1	EA	Cam 1.1/4
203	2600-193	1	EA	Crank Handle Model 9200
205	2600-214	3	EA	Spring Clip For Crank Handle
211	2599-034	1	EA	Label Gate Operator
213	2599-199	1	EA	Label Universal
221	2600-485	1	EA	Chain #50 20' +Master Link
225	2616-815	2	EA	Stud Fully Threaded 3/4x10x6"
227	2600-969	2	EA	Bracket Chain 920 Zinc Plated
240	2599-100	2	EA	Sign Warning
249	2615-652	4	EA	Bolt Carriage 5/16-18 x 5/8
250	2615-681	12	EA	Bolt Carriage 1/2"x13x1"

251	2615-605	2	EA	Bolt Carriage 10-32 x 1/2
252	2615-625	5	EA	Bolt Carriage 1/4-20 x 1/2
253	2615-696	2	EA	Bolt Carriage 1/2-13 x 4"
254	2615-678	6	EA	Bolt Carriage 3/8-16 x 1
255	2615-154	16	EA	Bolt Hex Head 5/16-18 x 1
256	2615-052	8	EA	Bolt Hex Head 3/8-16 x 1
257	2615-002	2	EA	Bolt Hex Head 1/4x20x1/2length
259	2615-677	12	EA	Bolt Carriage 3/8-16 x 3/4
260	2616-000	10	EA	Screw Phillips Head 6-32 x 1/4
261	2600-887	2	EA	Screw Nylon Phillips 6-32x1/4"
265	2616-103	6	EA	Screw Pan Head 4-40 5/8"
266	2616-003	13	EA	Screw Phillips Head 6-32 x 3/4
267	1816-039	2	EA	Screw 10-32 x 1/4"
269	2616-017	8	EA	Screw Phillips Head 8-32 x 3/8
270	2616-052	4	EA	Screw Phillips Head 10-32 x1/2
271	2616-031	2	EA	Screw Flat Head #0-90x1/4 Slot
280	2620-021	10	EA	Washer 1/2 " SAE
281	2802-003	4	EA	Washer #8 SAE
282	2802-002	1	EA	Washer #6 SAE
283	2620-010	5	EA	Washer #10 SAE
290	2620-050	14	EA	Lockwasher 1/2"
291	2620-047	28	EA	Lockwasher 3/8"
292	2620-053	3	EA	Lockwasher 5/16"
293	2620-109	2	EA	Washer 1/4" Split Lock
300	2620-036	4	EA	Washer 1.483 ODx.813 IDx.116 T
312	2620-409	12	EA	Nut Hex Flange Lock 1/4-20
313	2902-004	5	EA	Nut Nylon Lock 8-32
314	2620-420	14	EA	Nut Hex 1/2-13
315	2620-405	10	EA	Nut Hex 3/8-16
316	2902-006	9	EA	Nut Nylon Lock 10-32
318	2620-411	20	EA	Nut Hex Flange Lock 5/16-18
319	2902-003	24	EA	Nut Nylon Lock 6-32
320	2902-010	1	EA	Nut Nylon Lock 8-32 Green
322	2620-430	4	EA	Nut Hex 3/4"x10
323	2620-399	2	EA	Nut Hex 00-90 Brass Zinc Plt